

Backscatter measurement by seafloor-mapping sonars

Basics and challenges

Xavier Lurton

Ifremer, France

Underwater Acoustics Dept

GEOHAB Workshop
Rome, 6 May 2013



Backscatter in seafloor-mapping

*Why do we want to measure and map
Seafloor Backscatter?*

Sonar measurement of seabed reflectivity

- Historically:
 - **Bottom echoes** = limitation for active sonars
 - **Side-scan sonar** development for seabed imaging (1960→)
 - A by-product of **swath bathymetry** MBES systems (1980→)
- Today:
 - A domain of its own, developing
 - Users = Geoscience, Naval, Environmental, Hydrography, Industry
- Expectations:
 - Basic **interpretation of seafloor scenes**
 - (Automated) **identification of seafloor type**
 - Quantified **estimation of seafloor parameters**

From the same echo...

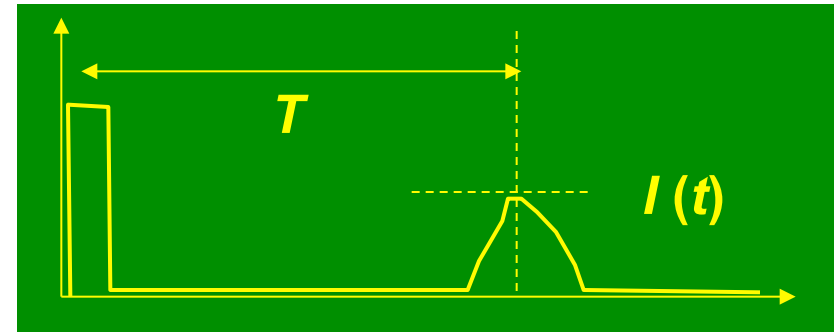
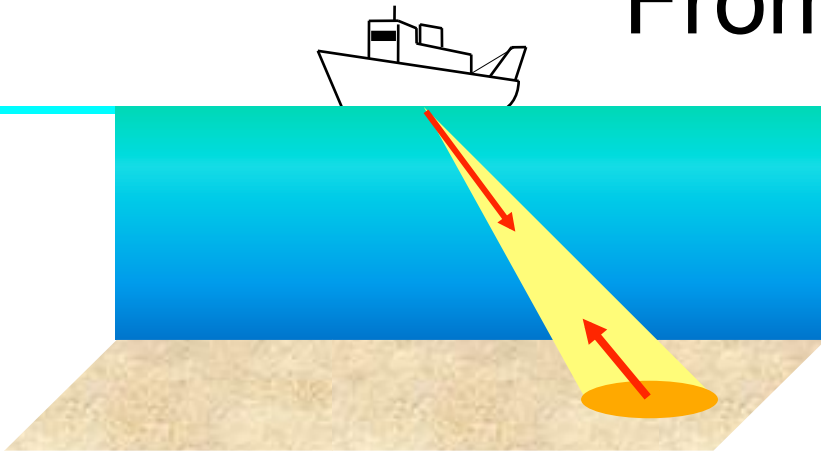

- Echo Delay → Range & Angle

- Target localisation
- Seafloor mapping
- ...

- Echo Intensity → Target Strength

- Target nature / structure
- Seafloor characterization
- ...

- Time, Phase
- Geometry
- Signal proc.

- Amplitude
- Physics
- Calibration

Terminology

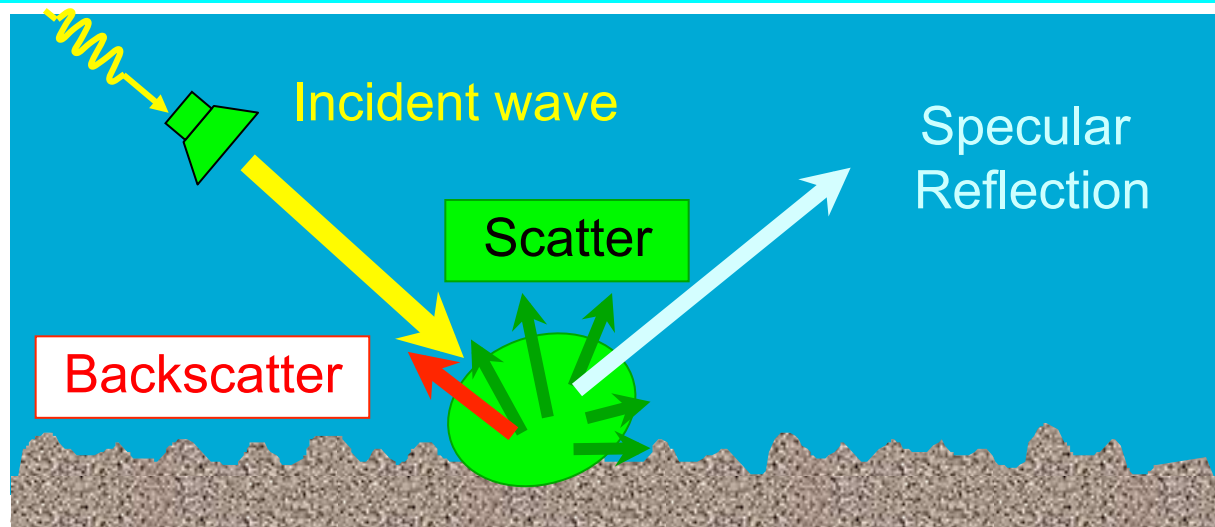

- **Reflection**
 - Coherent signal
 - Sent in specular direction
- **Backscatter**
 - Average intensity
 - Sent back to sonar
- **Reflectivity** = generic capability to send back incident intensity
- **Reverberation** = continuum of undesirable echoes (= clutter)

Target Strength

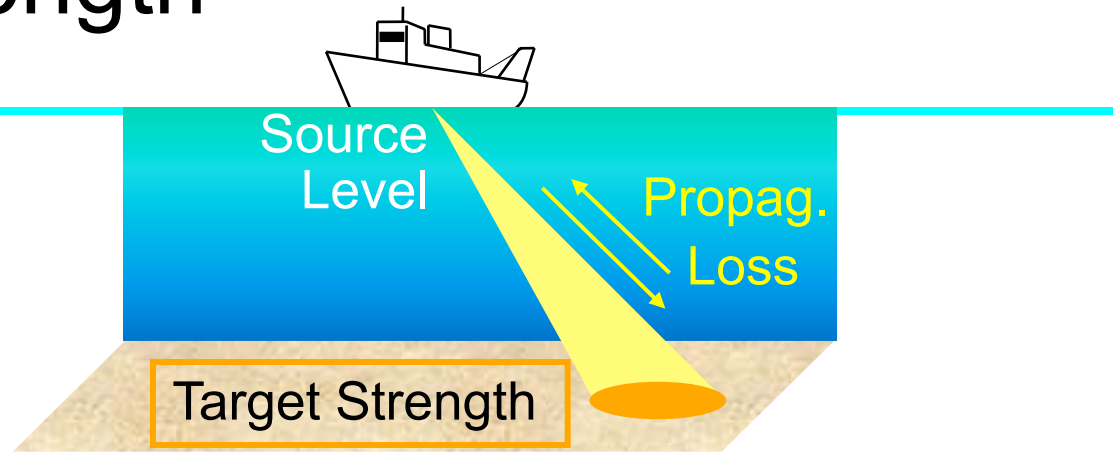

- TS = ratio backscattered intensity \Leftrightarrow incident intensity
- Sonar Equation (in dB):

$$EL = SL - 2 TL + TS$$

- EL = Echo Level
- SL = Source Level
- TL = Transmission Loss
- TS = Target Strength

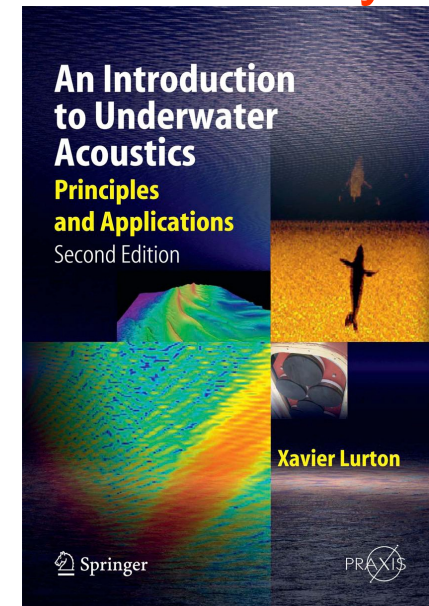

From *TS* to Seafloor *BS*

- Target Strength

$$TS = BS + 10 \log A$$

- ***BS = Backscatter Strength***

= Target Strength (dB) of 1 m² seafloor. Depends on:

- Seafloor type & characteristics
- Incident angle
- Frequency

- ***A = instant ensonified footprint*** area (m²). Depends on:

- Sonar aperture ; signal duration
- Measurement configuration (range, angle...)

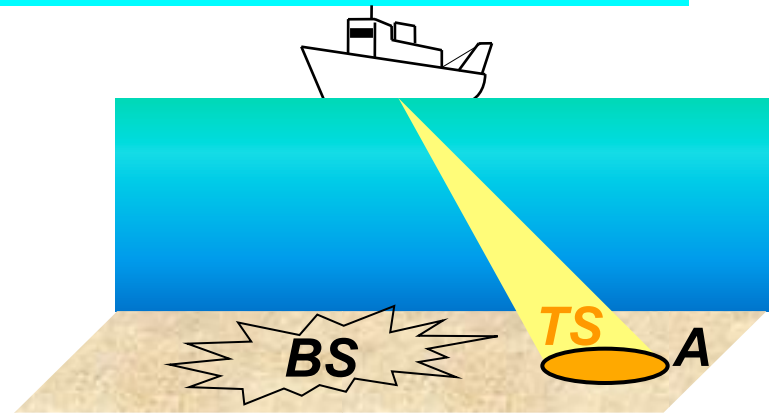

Backscatter processing

$$EL = SL - 2 TL + BS + 10 \log A$$

1st Step : retrieval

- measure EL
- compensation $TL \rightarrow TS$
- compensation $A, \theta \rightarrow BS$

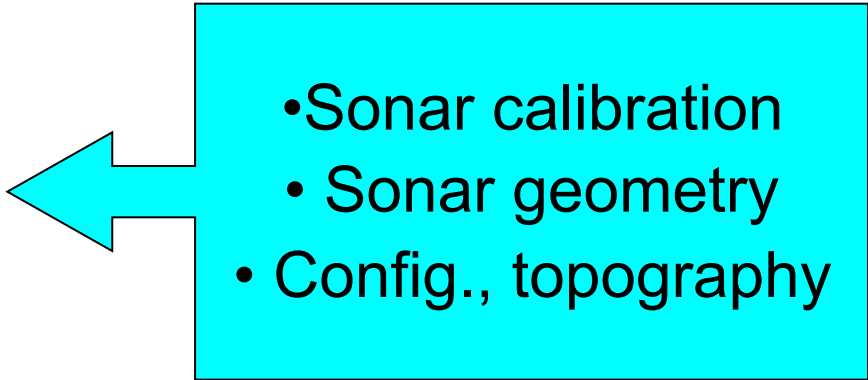
- 
- Sonar calibration
 - Sonar geometry
 - Config., topography

2nd Step : exploitation

- BS Display
- Descriptor extraction
- Classification & characterisation

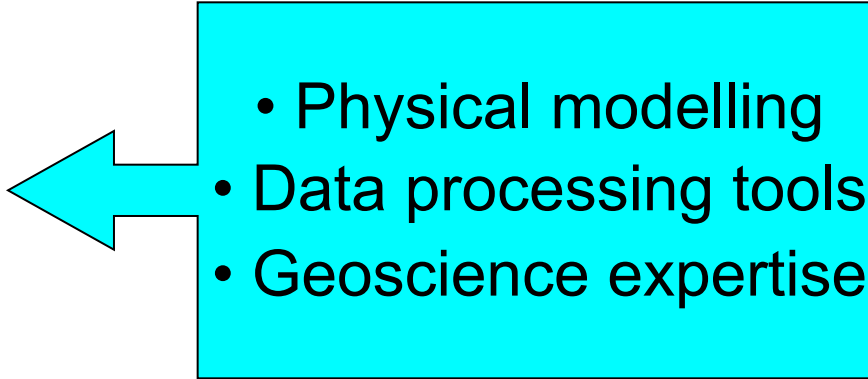
- 
- Physical modelling
 - Data processing tools
 - Geoscience expertise

Seafloor acoustic scattering = a mix of...

- **Impedance** contrast
 - Water vs sediment, rock...
- Interface **roughness**
 - Various scales
- **Volume** contribution
 - layers, bubbles, inclusions...
- Discrete **scatterers**
 - Animals, vegetation, minerals...



Data courtesy of UGMM (B)

A current assumption today :
Backscatter level = a (good?) proxy for seafloor
types and characteristics

New expectations in seafloor mapping



GEOHAB

Marine Geological and Biological
Habitat Mapping

- **Need of common/accepted procedures in Backscatter Processing**
 - Sonar calibration
 - Data formats
 - **For years in Fishery sonar & Satellite Radar**
 - **Nothing in Seabed survey / seabed characterization**
 - Survey strategies
 - Processing SW

Outline

- ~~1. Backscatter in seafloor mapping~~
- 2. Physical phenomena and modelling**
3. Backscatter processing
4. A detour by outer Space
5. MBES calibration issues
6. From backscatter data to seafloor characteristics
7. Discussions and prospective

Physical phenomena & modeling

How does it work?

How far can we model for a practical use?

Sedimentary seafloor scattering process

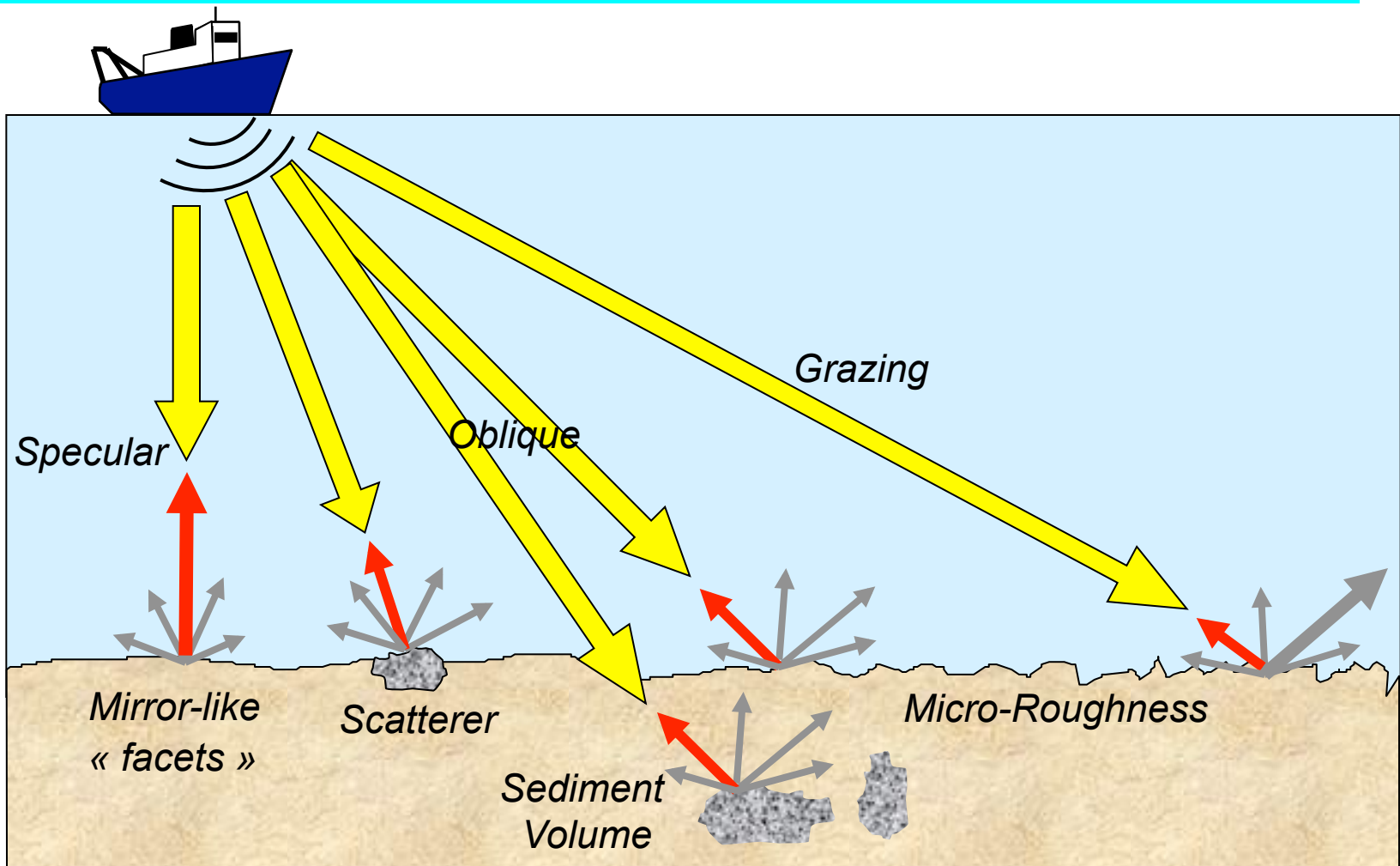

Seafloor scattering regimes vs Angle

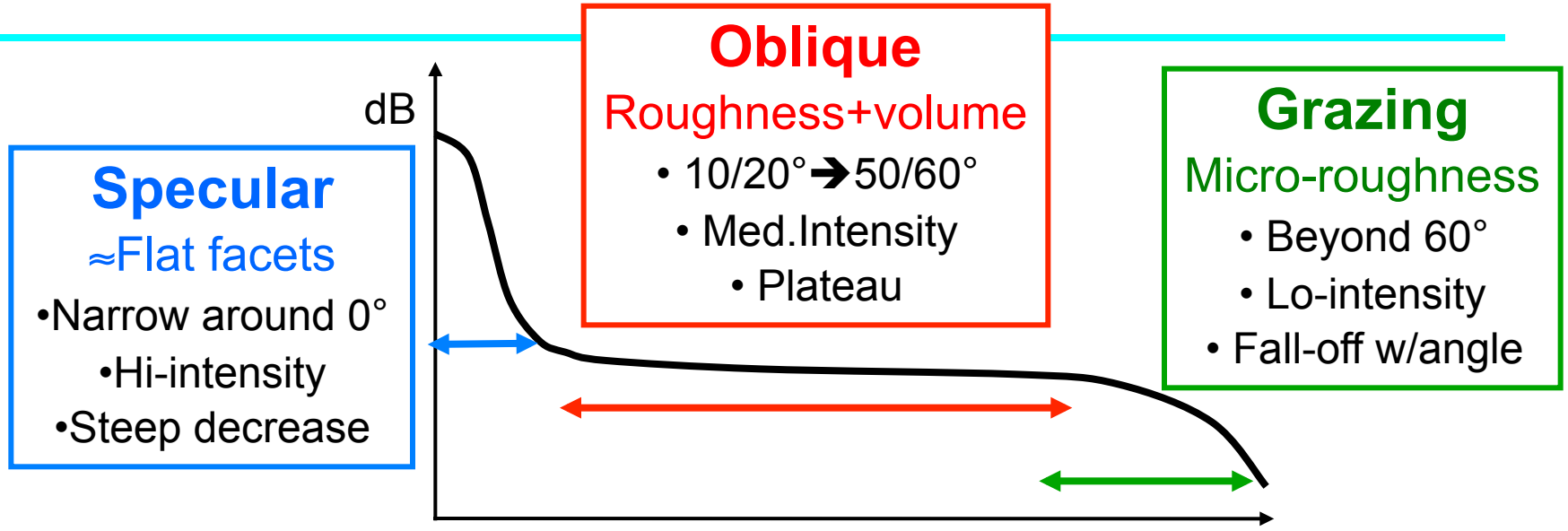

Balance between regimes depends on:

- Seafloor type
- Frequency

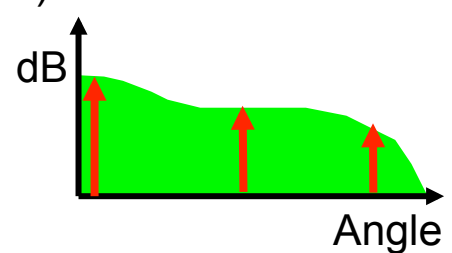
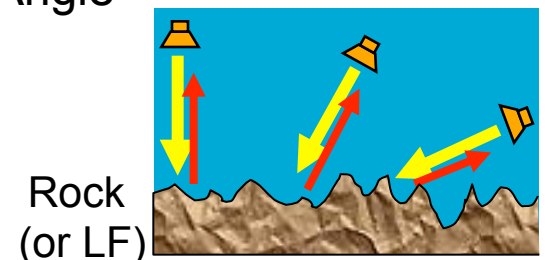
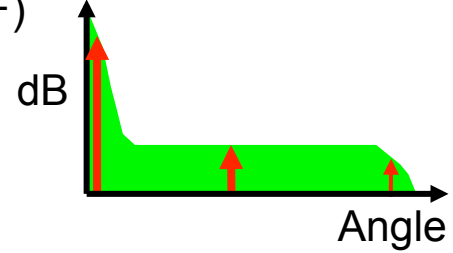
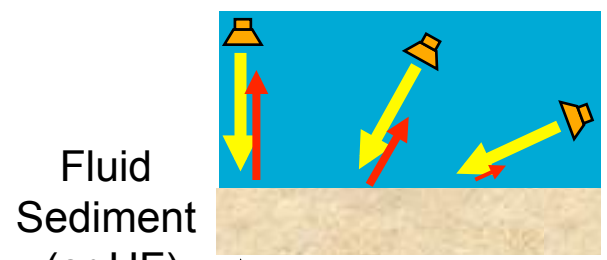

Seafloor BS modelling : many aspects

- **Seafloor acoustic properties & propagation**
 - Fluid / solid /...?
 - Homogeneous / Layered /...?
- **« Geoacoustics »**
 - Geological / acoustical relations
- **Rough interface backscattering**
 - Specular / Oblique
- **Volume scattering**
 - Layering / inclusions /...
- **Discrete scatterers**
 - Bubbles / Discrete scatterers / Vegetation...

Homogeneous sediment propagation

1. Dissipative fluid $\rightarrow \rho, c, \alpha$

2. Dissipative solid medium $\rightarrow \rho, c, \alpha, c_s, \alpha_s$

3. Porous medium (Biot, Stoll)

- Solid frame filled with seawater \rightarrow 13 parameters
- Three waves : fluid, frame & *slow wave*
- Difficult agreement w/ experience ; challenging inversion

4. Granular medium (Buckingham)

- Global behaviour = dissipative fluid
- Absorption and shear due to **interaction / grains**
- Acoustic properties depend on **grain size**
- Model consistency with observations

Heterogeneous sediment propagation

1. Interface Layer

- Water content → varying characteristics / a few cm
- Strong impact → reflection coefficient (*Ainslie*)

2. Sediment Layering

- Increasing complexity / # of parameters
- Effect depending / frequency (*Ivakin, Guillon...*)

3. Interface & Volume Scatterers

- Mineral, vegetal, biological
- Hard / Soft → predominant scattering or absorption
- May dominate the sediment acoustic behaviour

4. Gas bubbles

- CH_4 ; H_2S ; NH_3 ; biological, volcanic, thermal origin
- Strong impedance contrast + resonance → Reflective & absorbing layers
- May completely change the sediment properties

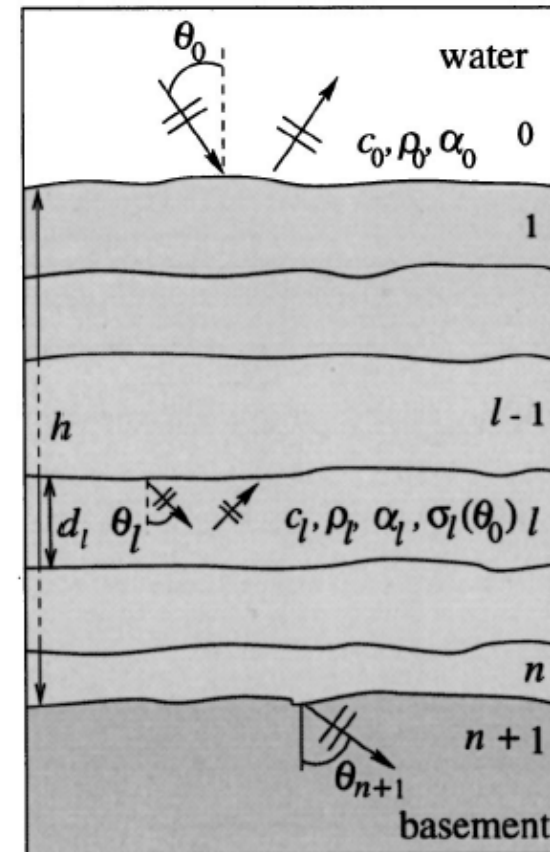

« Geoacoustics »

Which **relations** between **habitat** & **acoustical** properties?

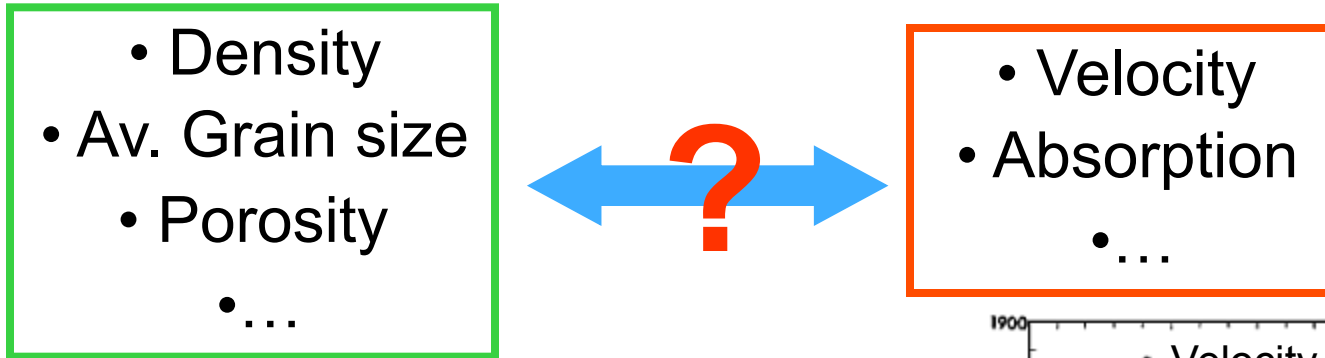

- Works by E.H. Hamilton (1980...)
 - Laboratory measurements + compilation
 - Density, velocity, absorption...
 - Strict methodology

➔ A unique corpus of data and results

➔ A reference for geoacousticians

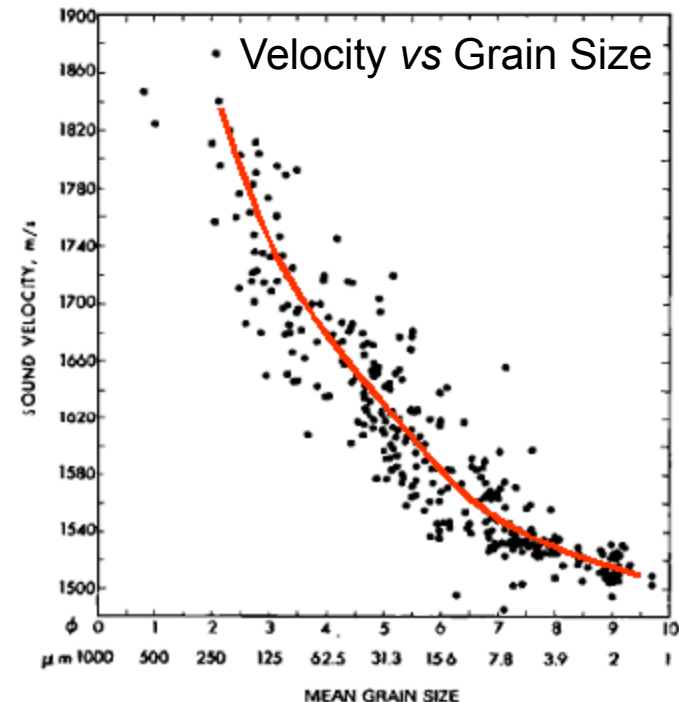

Geoacoustical Parameters

- **Mean Grain Size** in Phi units, with $M(\phi) = -\log_2(a)$;
- **Porosity** : volume percentage of water in the sediment ;
- **Density** (kg/m³)
- **Relative velocity** c_r (referenced to seawater)
- **Absolute velocity**, for a seawater value 1500 m/s
- **Reflection coefficient** at normal incidence $V(0^\circ)$, in dB
- **Absorption coefficient** α , in dB/ λ
- **Shear velocity** c_s , in m/s
- **Spectral index of roughness** Ω_0 , in cm⁴
- **Roughness standard deviation** over unit distance h , in cm
- **Slope standard deviation** δ , in degrees

Geoacoustic models

- Typical orders of magnitudes of geoacoustical characteristics can be synthesised from Hamilton's works

<i>Sediment type</i>	M	n	ρ	c_r	c	$V(0^\circ)$	α	c_s	Ω_0	h	δ
	ϕ	%	kg.m ⁻³		m/s	dB	dB/ λ	m/s	m ⁴	cm	°
Clay	9	80	1200	0.98	1470	-21.8	0.08	/	5x10 ⁻¹²	0.5	1.2
Silty Clay	8	75	1300	0.99	1485	-18.0	0.10	/	6x10 ⁻¹²	0.5	1.5
Clayey Silt	7	70	1500	1.01	1515	-13.8	0.15	125	7x10 ⁻¹²	0.6	1.7
Sand-Silt-Clay	6	65	1600	1.04	1560	-12.1	0.20	290	8x10 ⁻¹²	0.6	2
Sand-Silt	5	60	1700	1.07	1605	-10.7	1.00	340	9x10 ⁻¹²	0.7	2.5
Silty Sand	4	55	1800	1.10	1650	-9.7	1.10	390	1x10 ⁻¹¹	0.7	3
Very Fine Sand	3	50	1900	1.12	1680	-8.9	1.00	410	2x10 ⁻¹¹	1.0	4
Fine Sand	2	45	1950	1.15	1725	-8.3	0.80	430	3x10 ⁻¹¹	1.2	5
Coarse Sand	1	40	2000	1.20	1800	-7.7	0.90	470	7x10 ⁻¹¹	1.8	6

(From Lurton *An Introduction to UWA*, 2nd Ed., 2010)

Facets model *(aka Kirchhoff approx.)*

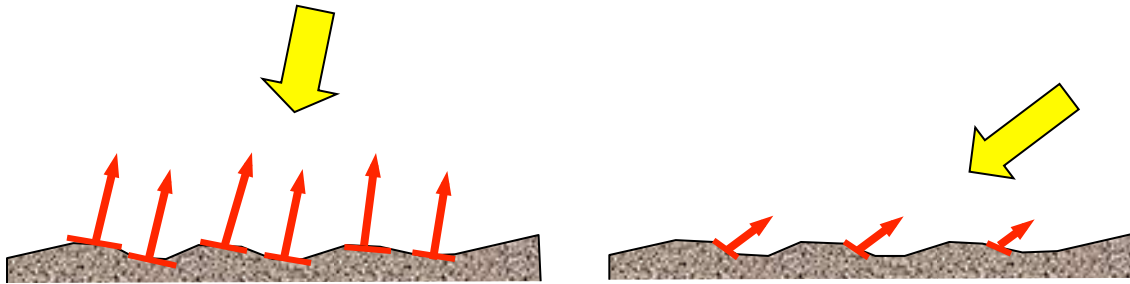

Interface \approx a mosaick of **facets**

→ specular echoes, function of angle.

Vertical incidence : many horizontal facets → **Intensity** ↗ max.

Oblique incidence : less and less active facets → **Intensity** ↘ 0

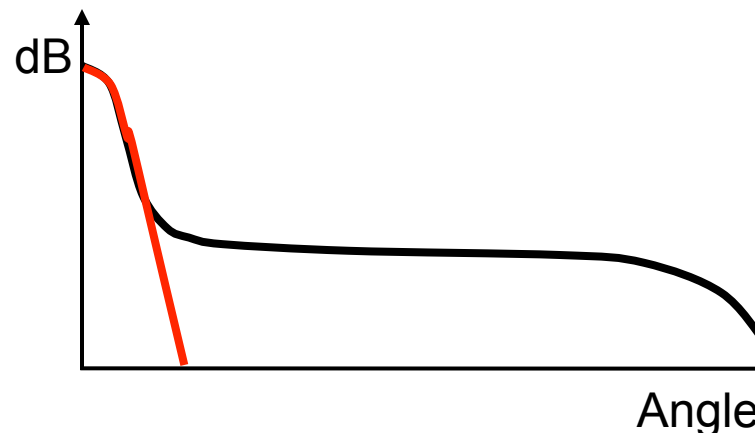

Bragg scattering *(aka Small-perturbation model)*

- At observation angle $\theta \rightarrow$ signal dominated by contributions from **in-phase scatterers**, spaced by d such as $2d \sin \theta = \lambda$

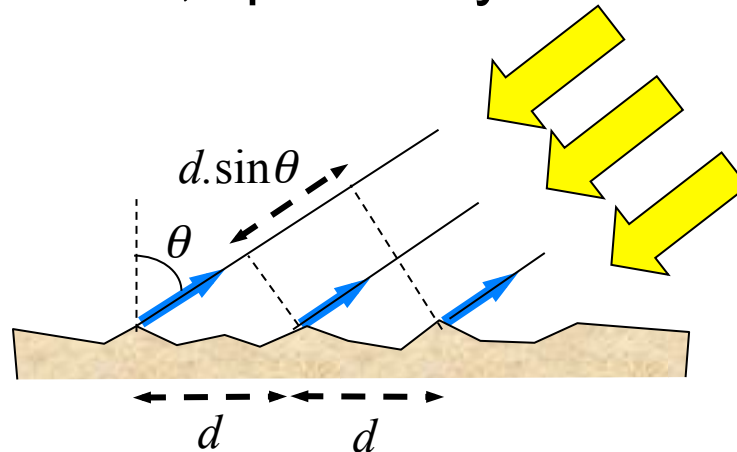

- Main contribution : spectrum component $\kappa = 2k \sin \theta$

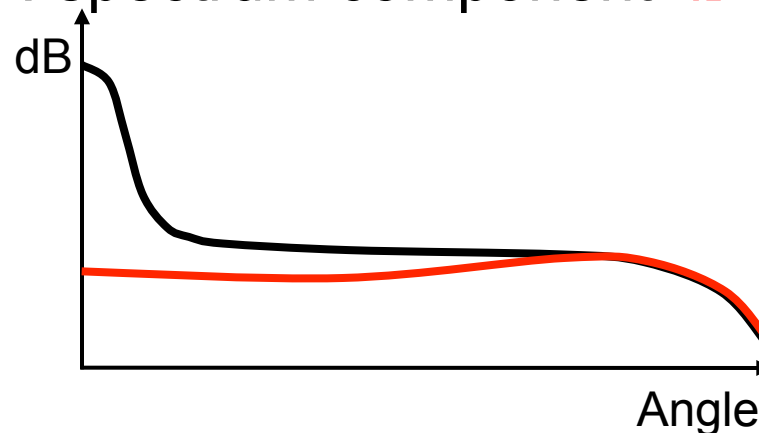

Roughness scales

Backscatter is impacted by **all roughness scales**:

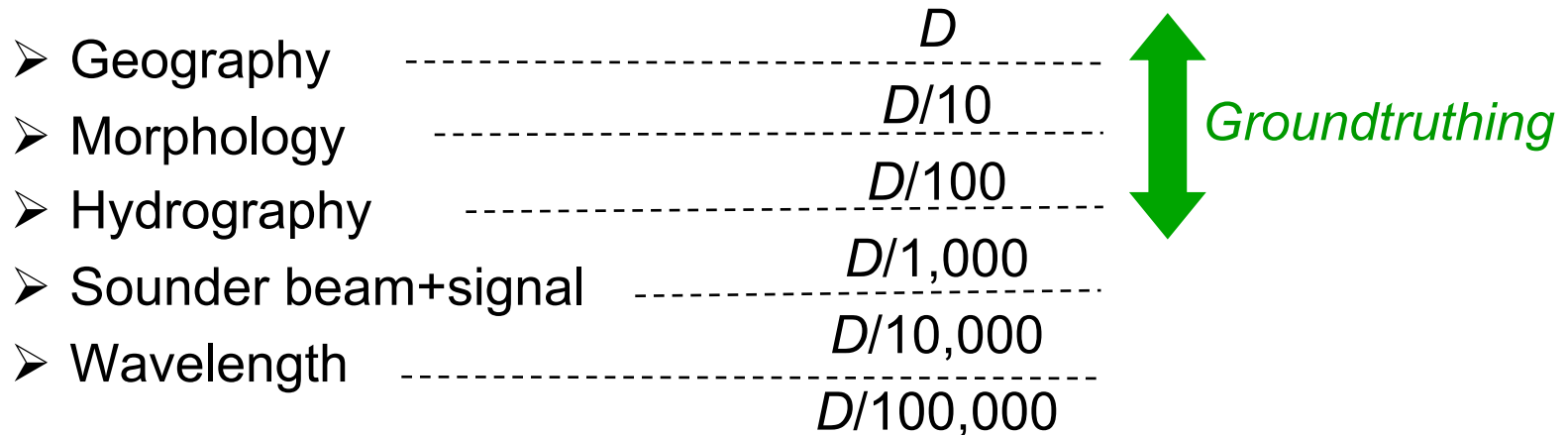

- Large-scale effects (Geo→Hydrography) are separable
 → processed geometrically (from DTMs)
- Small-scale remains within the sounder resolution
 - Modelling : *Composite-roughness*
 - Practically not separable – nor accessible to groundtruthing

Volume contribution

- Often **prevalent at intermediate** oblique incidence
- **Geometrical / Sonar equation**
- Very strong influence of **frequency**
 - **LF** → **lo absorption + lo scattering**
 - **HF** → **high absorption + high scattering**
- Well understood...but need a **“magic number”** at some point:
 - Mean volume Backscatter Index BS_v
 - Fluctuation rate/scale in $c, \rho...$
- Groundtruthing = difficulty +++

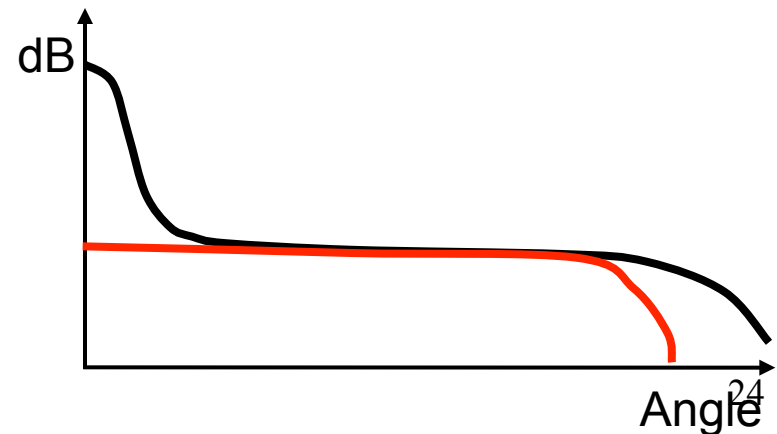
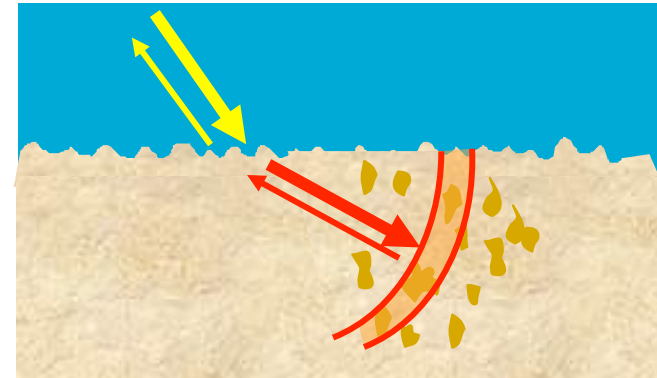

Backscattering: Discrete scatterers

- Minerals, vegetals, animals... & gas bubbles
- **Paramount for Habitat mapping** 
- Could such **scatterers dominate** the seafloor response?
 - **YES**: fields of stone, shells, vegetation...
 - A question of scale, configuration, density...
- The less-often studied phenomenon (excl. Bubbles)
 - Exceptions: *Stanton, Lyons...*
- Little quantitative models available for such scatterers :
 - Neither for individuals, nor for collective BS
 - Not very rewarding for modelers?
 - Should such models make sense?

The classical “Jackson model”

- Geoacoustical validity :
 - Sediment = dissipative homogeneous fluid
 - Roughness = isotropic - exponential law spectrum
 - Volume : free parameter

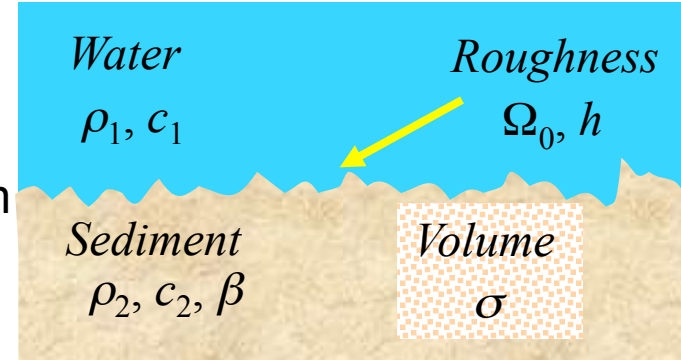

- Three components :

- **Facets** / Kirchhoff → close/ vertical
- **Composite roughness** → grazing angles
 - **Volume** → intermediate oblique

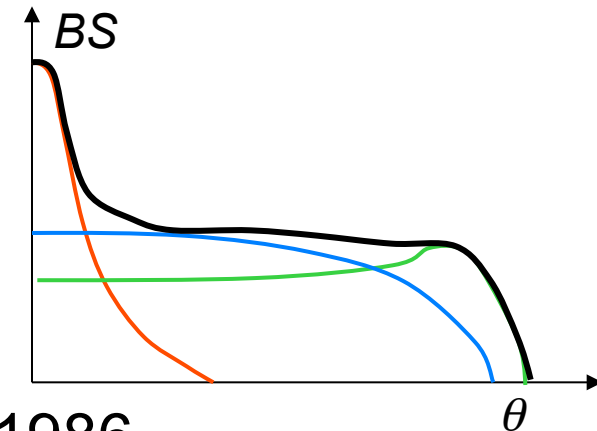

- Frequency validity ≈ 10 -100 kHz

- Many reference papers (JASA) since 1986
- A reference model – widely appreciated and used

The Jackson model: pros and cons

- 😊 Solid theoretical bases
 - 😊 Careful validations
- 😊 Good physical approach
- 😊 Acceptable complexity
 - 😊 6 parameters
 - 😊 Algorithm
 - 😊 Invertible

- 😞 Medium = too idealized
 - 😞 Homogeneous fluid sediment
 - 😞 Isotropy / azimuth
- 😞 Many config. not covered
 - 😞 Sediment ripples...
 - 😞 Rocks, pebbles, gravels...
 - 😞 Scatterers, vegetation...
- 😞 Inversion ambiguities



- An **excellent academic benchmark**
 - Certainly **not universal**
 - Probably **overused**
- Confrontation / **reality** may be **disappointing...**

The “APL model”

- Basically the Jackson’s model expressed for a number of geoacoustical configs for sediments
- Completed by empirical formulae for non-sediment seafloors

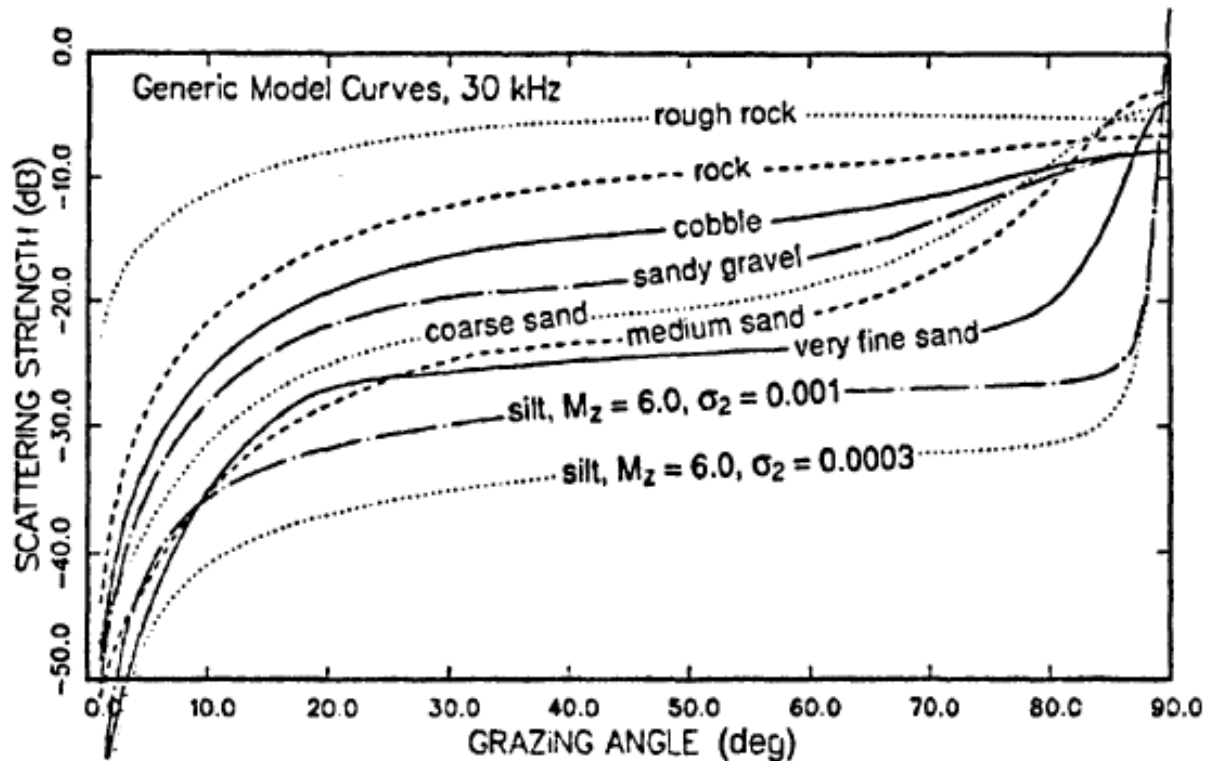

Heuristical models

- Used for long: empirical models built from:
 - Experimental data
 - A basic model - or no model at all
 - e.g. **Lambert's law** $BS = BS_0 + 20\log(\cos\theta)$
 - Parametered by: angle, freq., seabed type
- **GSAB = a functional model of $BS(\theta)$**

$$BS = A \cdot \exp(-\theta^2/B) + C \cdot \cos^D \theta + E \cdot \exp(-|\theta|/F)$$
 - Limited set of parameters (4 or 6)
 - Maximal generality
 - General agreement w/ physical response
 - Lamarche et al. *Cont.Shelf Res.* 2010

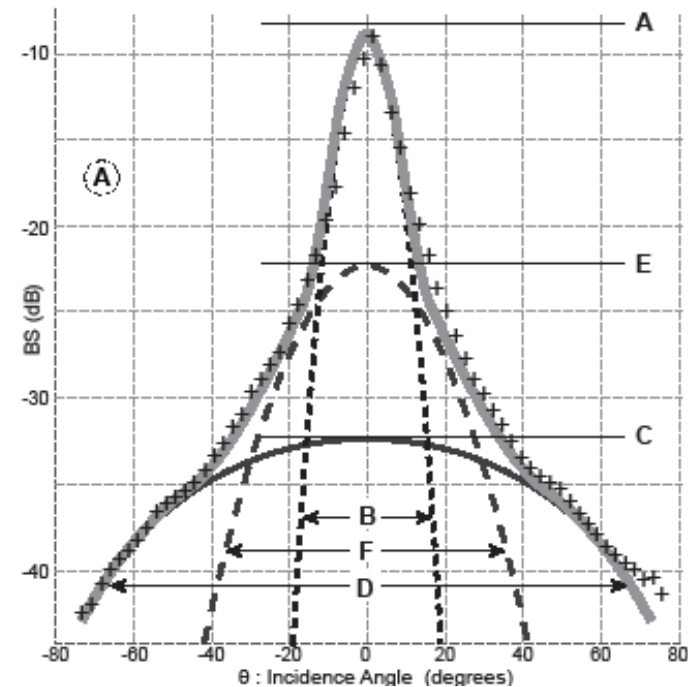

Azimuth dependence

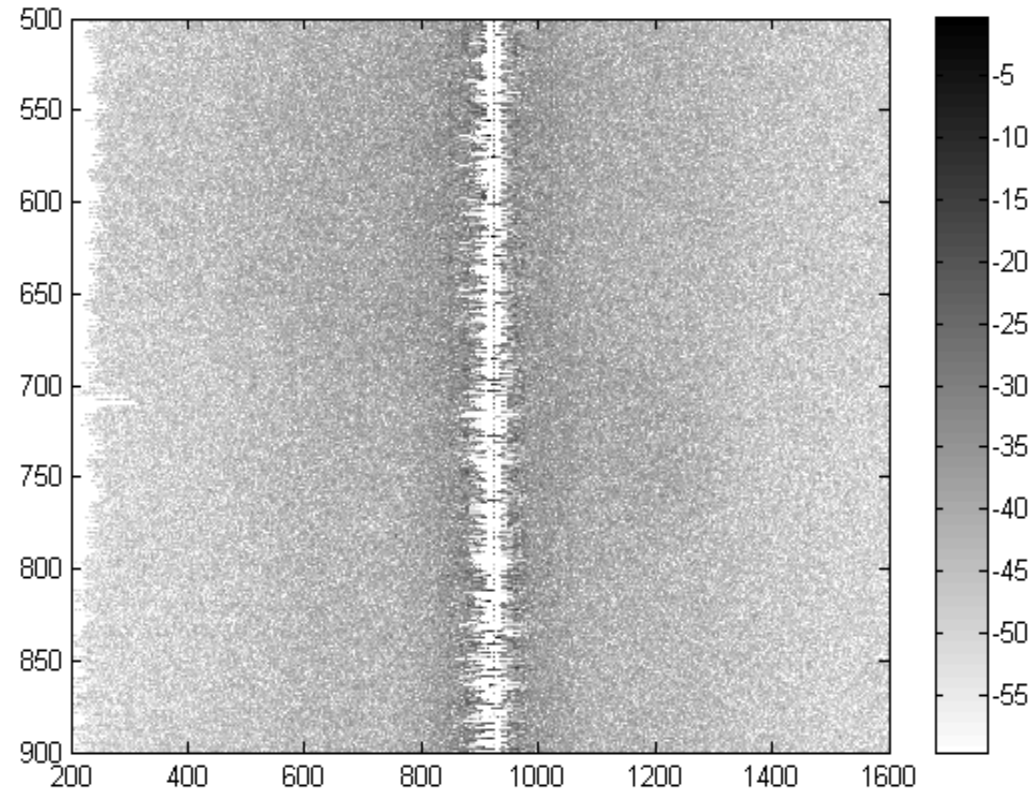
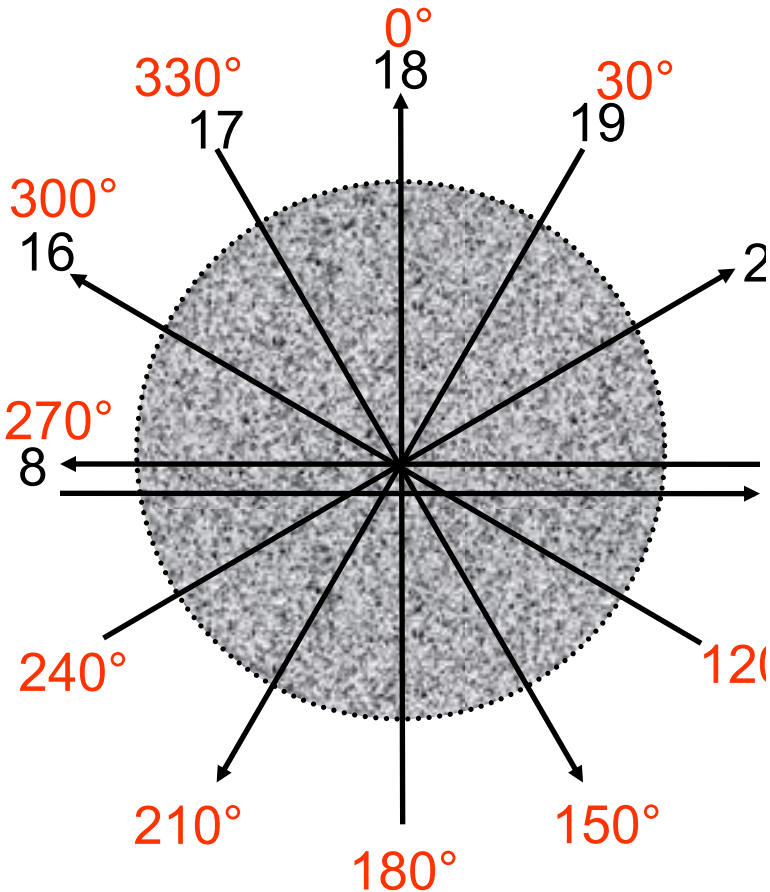

— Direction of ship's heading
 — Azimuthal angle of measurement

G. Le Chenadec, Ifremer (2004)

Azimuth dependence

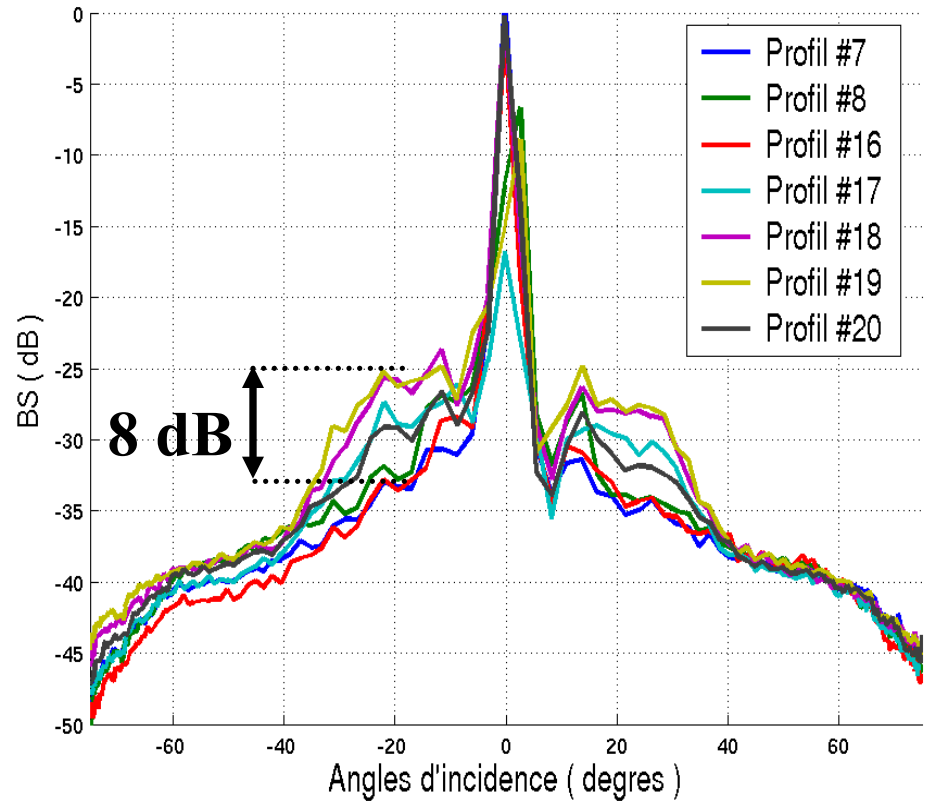
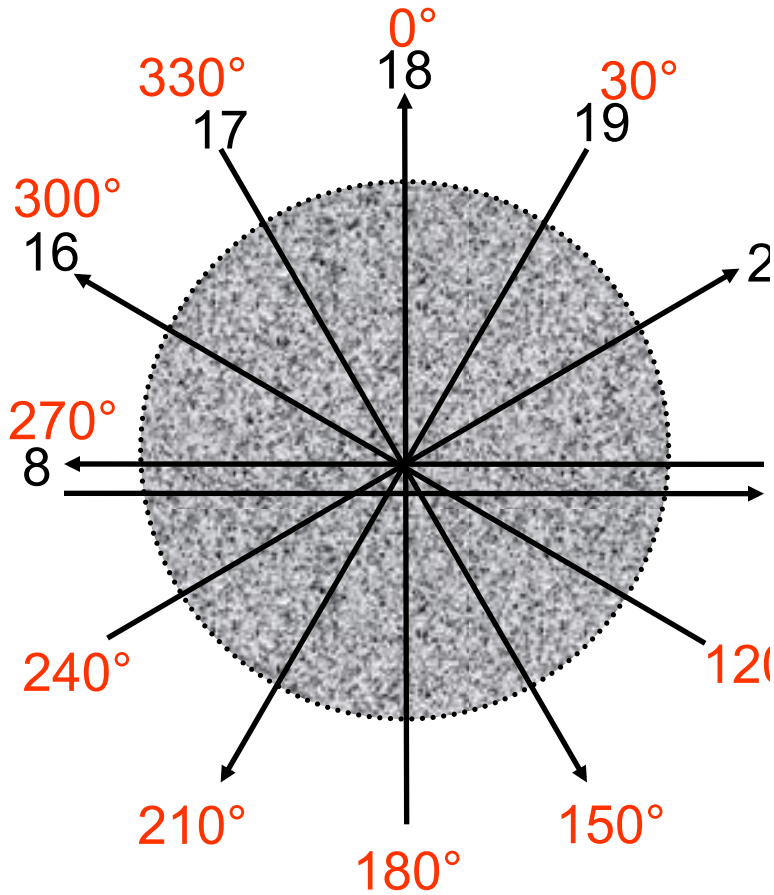

— Direction of ship's heading
 — Azimuthal angle of measurement

G. Le Chenadec, Ifremer (2004)

Azimuth dependence

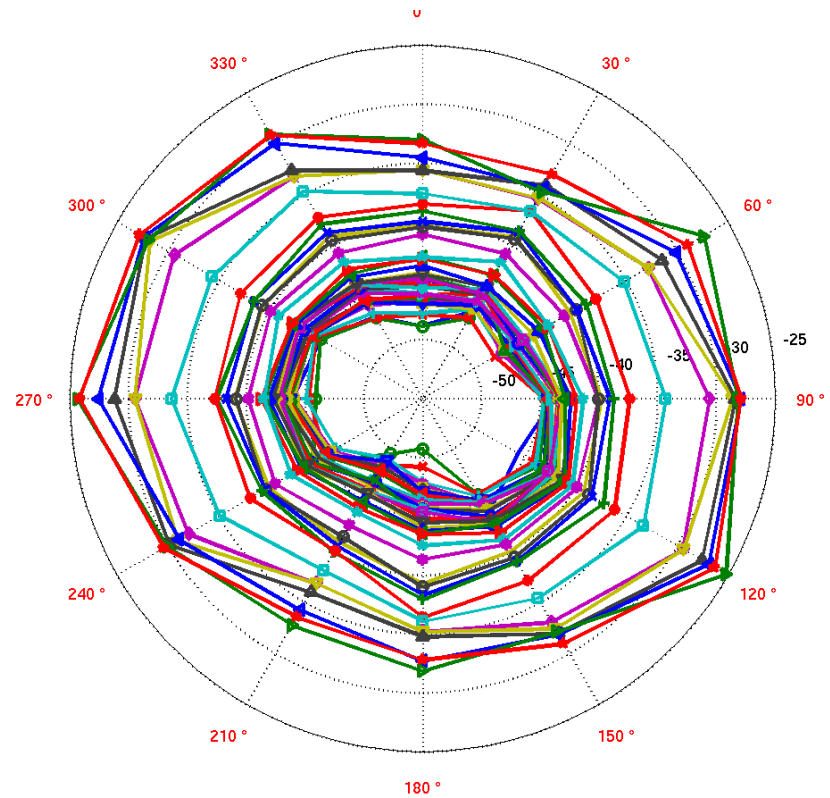
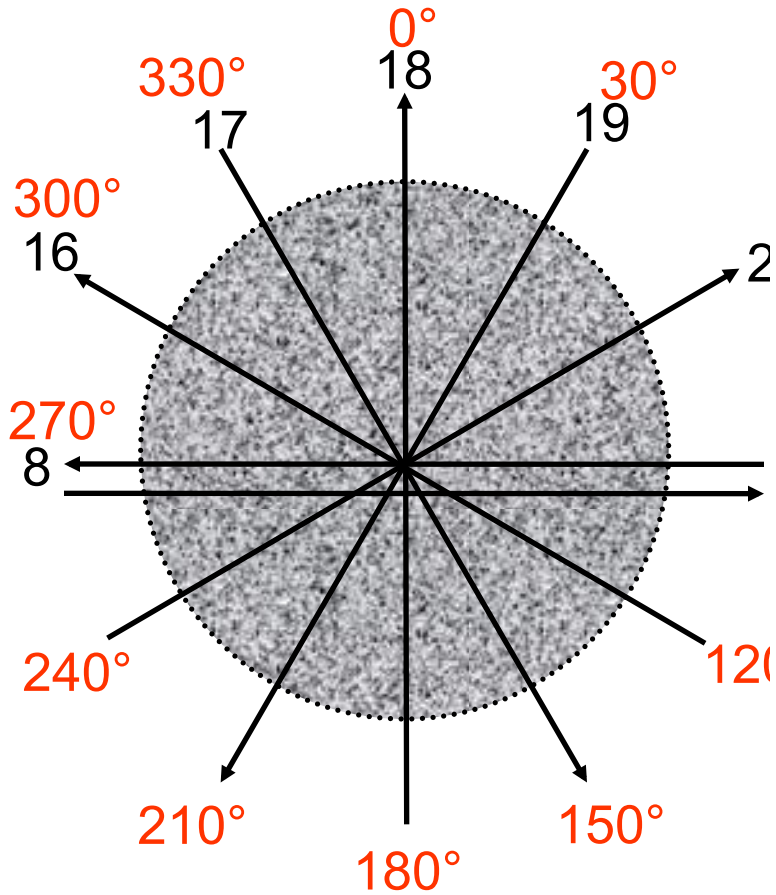

— Direction of ship's heading
 — Azimuthal angle of measurement

G. Le Chenadec, Ifremer (2004)

Modelling the footprint extent

- Instant projection of the backscattered signal
- Limited by (1) signal duration (2) beamwidth

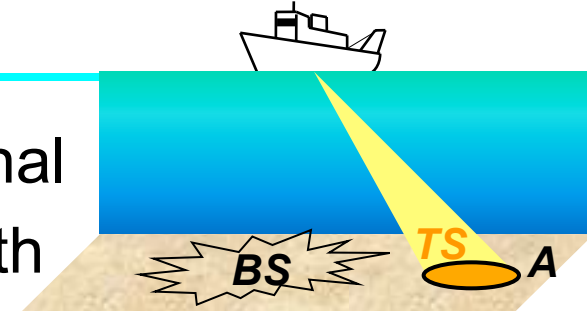

$$\delta y = c \cdot T / 2 \sin \theta$$

$$\delta x = \phi R = \phi H / \cos \theta$$

→ **Inhomogeneous** over the swath

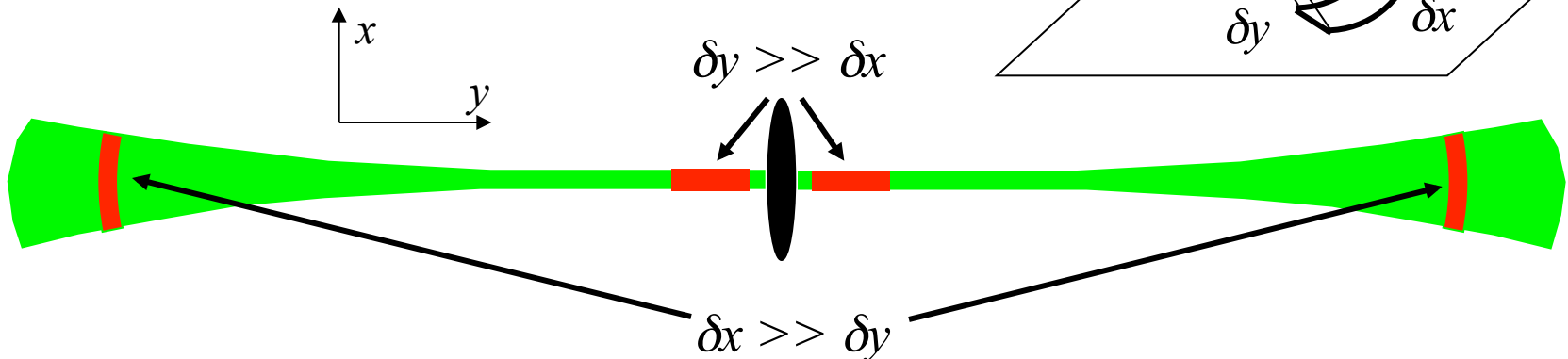
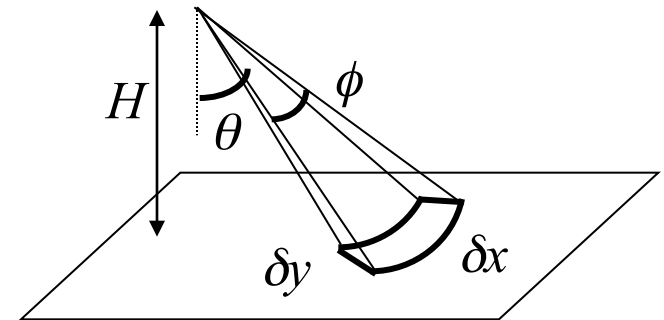

Should always account for **local topography** (x-y slopes)

The Water Column impact

- Classical compensation vs range R

$$TL = 20 \log R + \alpha \cdot R$$

= geometrical divergence + visco-thermal absorption

- $20 \log R$ may be modified by refraction
- α depends on:
 - Water characteristics
 - **Depth**
 - Frequency
- Other causes of absorption:
 - **Bubbles**
 - Fish, plankton...
 - Which control on these?

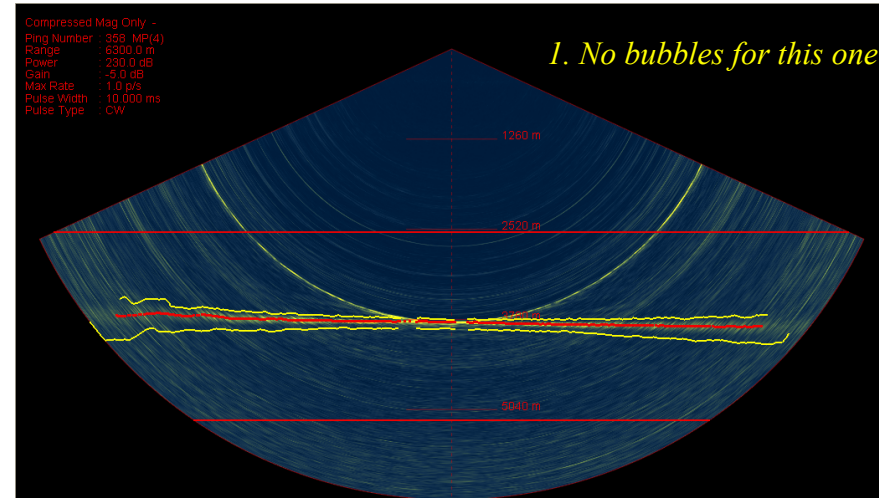

The Water Column impact

- Classical compensation vs range R

$$TL = 20 \log R + \alpha \cdot R$$

= geometrical divergence + visco-thermal absorption

- $20 \log R$ may be modified by refraction
- α depends on:
 - Water characteristics
 - **Depth**
 - Frequency
- Other causes of absorption:
 - **Bubbles**
 - Fish, plankton...
 - Which control on these?

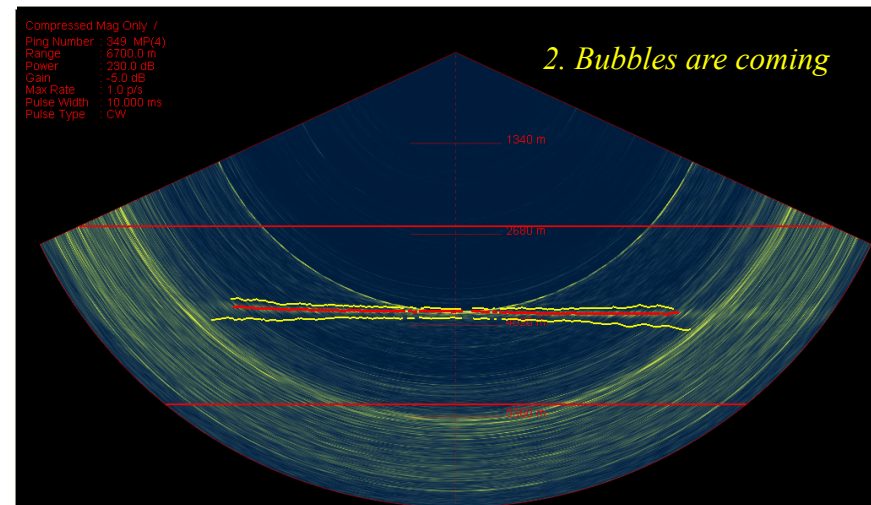

The Water Column impact

- Classical compensation vs range R

$$TL = 20 \log R + \alpha \cdot R$$

= geometrical divergence + visco-thermal absorption

- $20 \log R$ may be modified by refraction
- α depends on:
 - Water characteristics
 - **Depth**
 - Frequency
- Other causes of absorption:
 - **Bubbles**
 - Fish, plankton...
 - Which control on these?

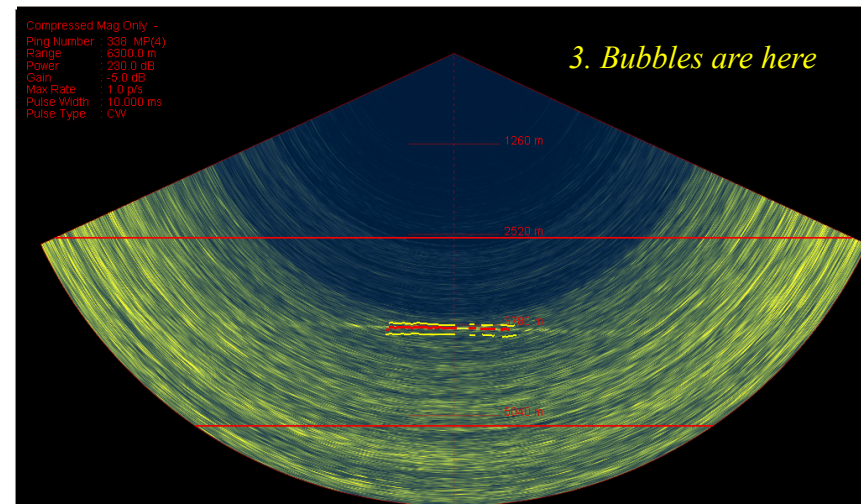

The Water Column impact

- Classical compensation vs range R

$$TL = 20 \log R + \alpha \cdot R$$

= geometrical divergence + visco-thermal absorption

- $20 \log R$ may be modified by refraction
- α depends on:
 - Water characteristics
 - **Depth**
 - Frequency
- Other causes of absorption:
 - **Bubbles**
 - Fish, plankton...
 - Which control on these?

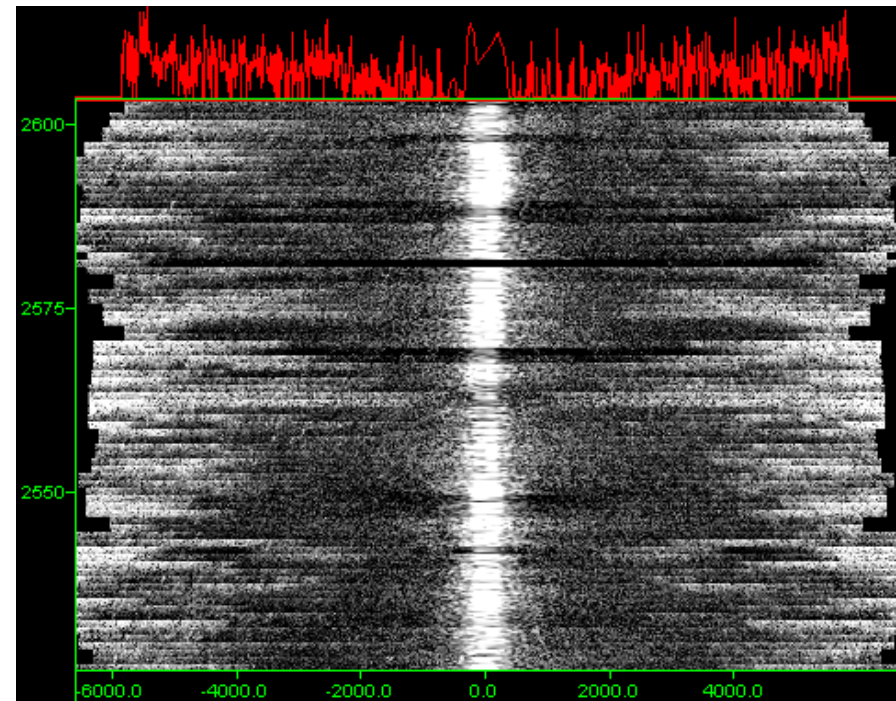

Models: Too simplistic / Too complicated?

- BS theoretical models = built on **simplifying hypotheses**
- Actual seafloor **complexity = always beyond the model's**
- One model **cannot make it for all seafloors**
- Modelling & inversion imply a **preliminary choice**
- Classical models feature **too high a number of parameters**
- Lacks of modelling for:
 - Very coarse sediments → Pebbles, boulders → Rocks
 - Shells, vegetation,...
 - Organized roughness (ripples...)
 - Composite interfaces
 - Azimut dependence
 - Water column impact

Outline

- ~~1. Backscatter in seafloor mapping~~
- ~~2. Physical phenomena and modelling~~
- 3. Backscatter processing**
4. A detour by outer Space
5. MBES calibration issues
6. From backscatter data to seafloor characteristics
7. Discussions and prospective

3. Backscatter processing

What can we do today?

Processing Operations

- **Data compensation** → **calibrated** data
 - Sonar parameters
 - Pulse length, beam width, settings...; Tx-Rx sensitivities
 - Environment parameters
 - Transmission losses; incident angle
- **Segmentation** → areas of **homogeneous acoustic** features
 - From BS/ angle
 - From Image texture
- **Classification** : acoustic facies → **seafloor types**
 - Model inversion
 - Ground-truthing
- **Inversion** : Data + model → seafloor **characteristics**
 - Acoustic parameters
 - Geological features

Reflectivity processing

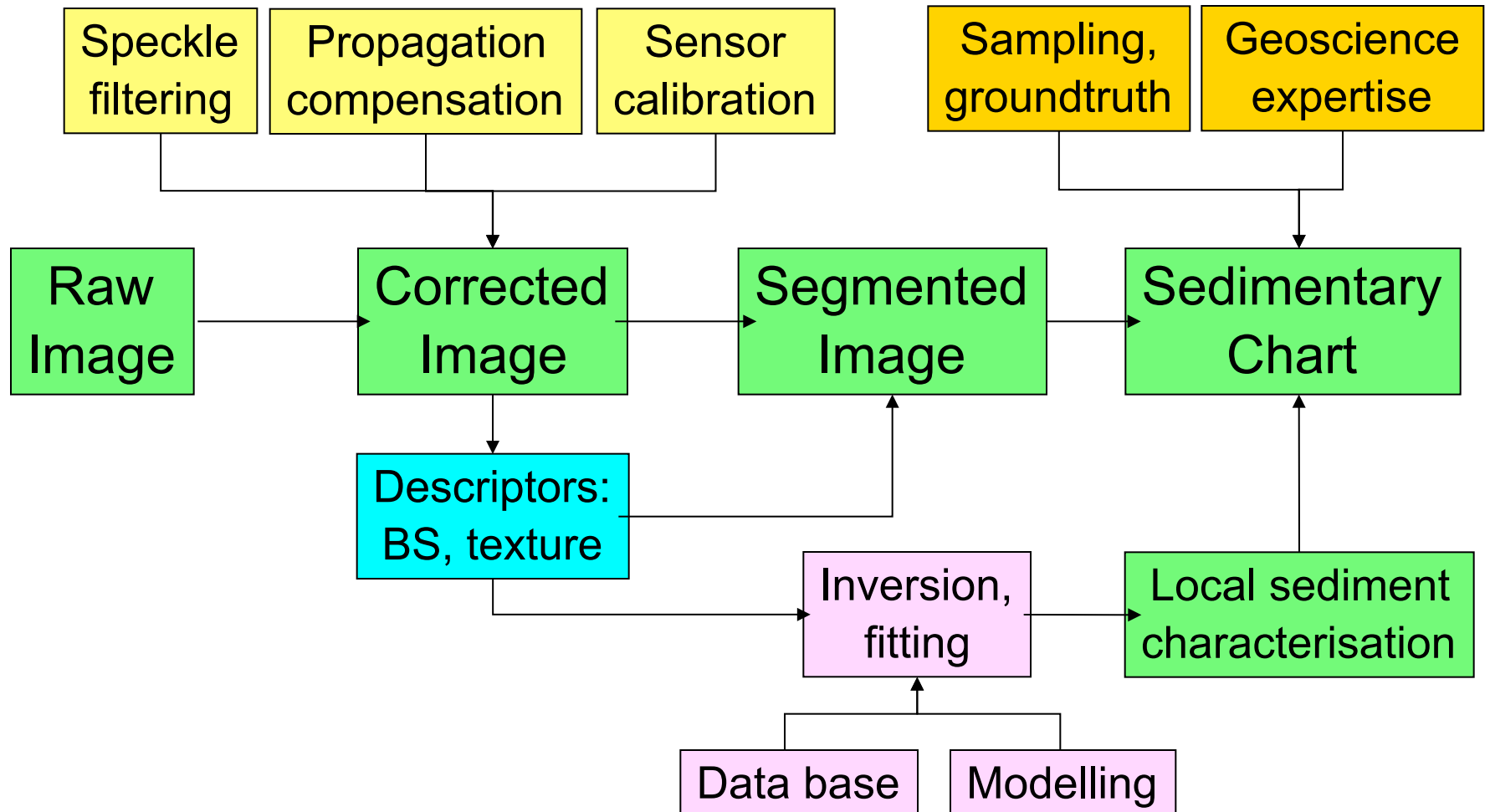

Processing steps for image compensation

- Multibeam Kongsberg EM300 (30 kHz)
- Water depth 950 m. Flat & homogeneous seafloor

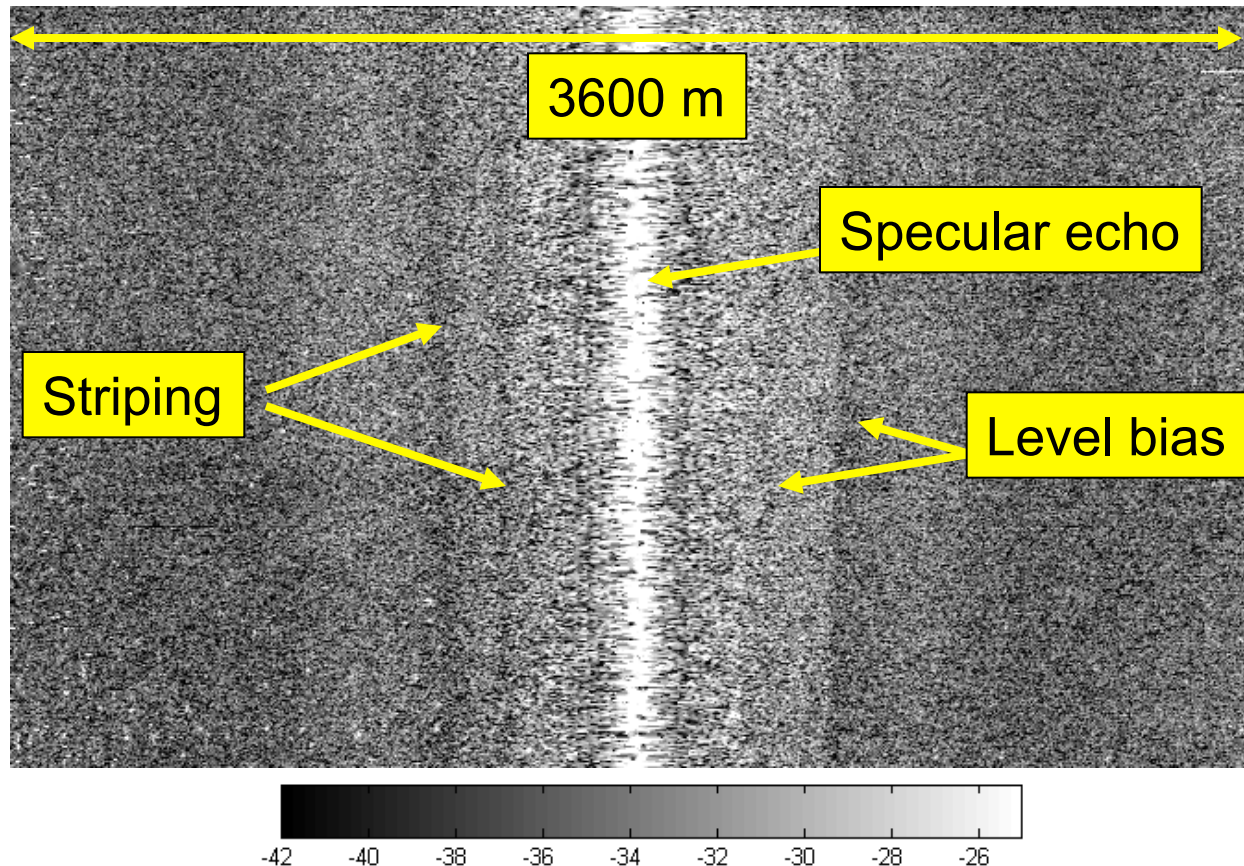

Analysis : Array directivity + BS effect

Seabed image

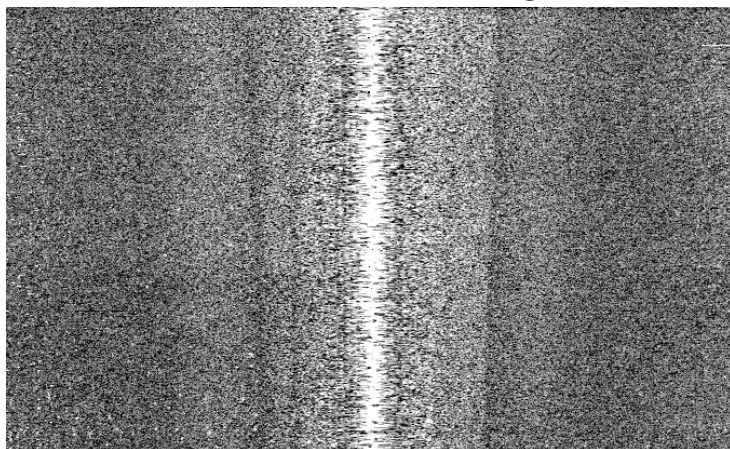

Tx sector

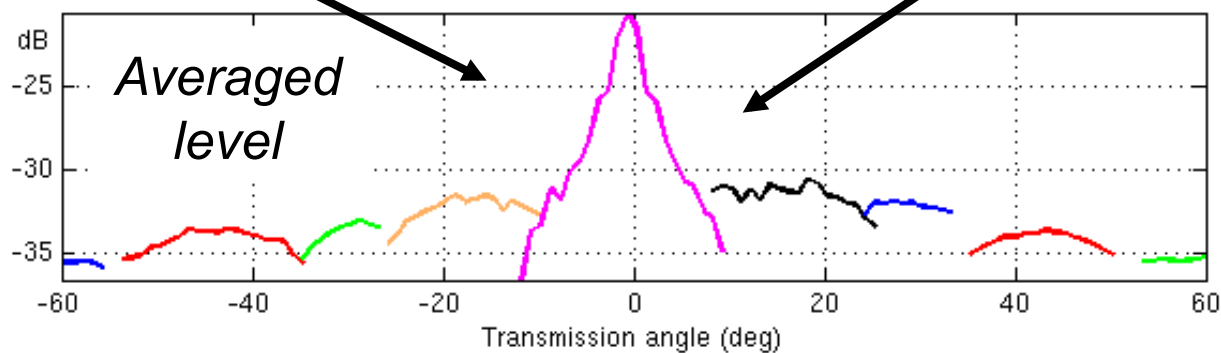
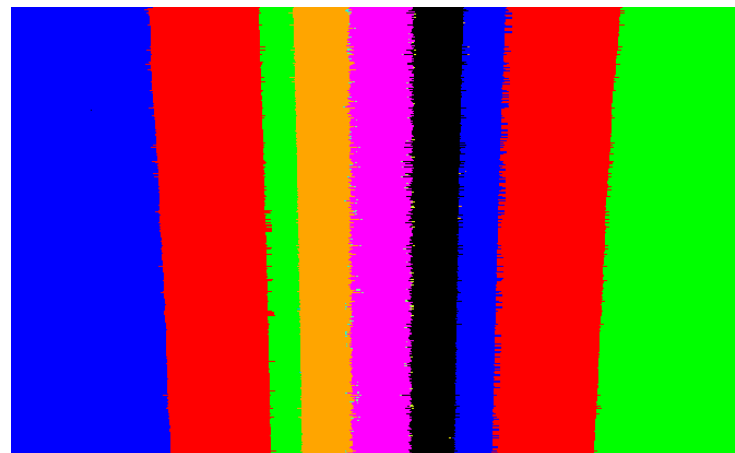

Angle-dependence compensation steps

- Fit an average BS(θ)
- Identify the sonar's influence

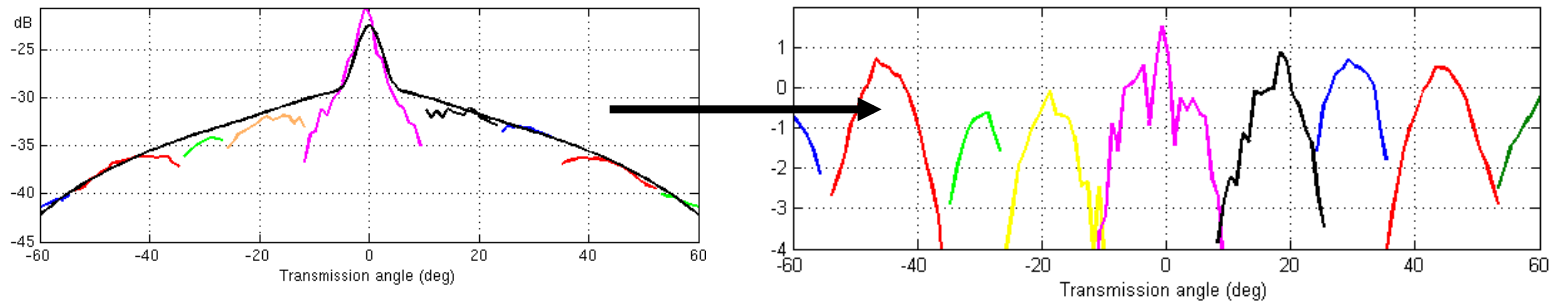

- Remove average BS and sounder directivity patterns
➔ compensated angular reflectivity

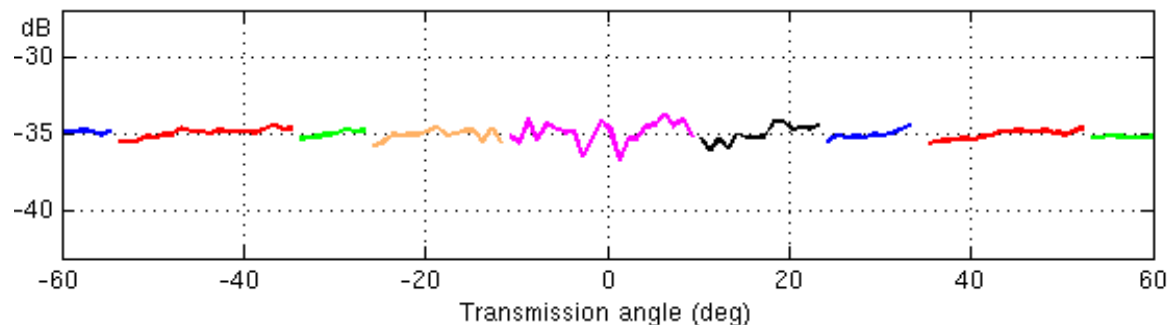

From raw to angle-compensated image

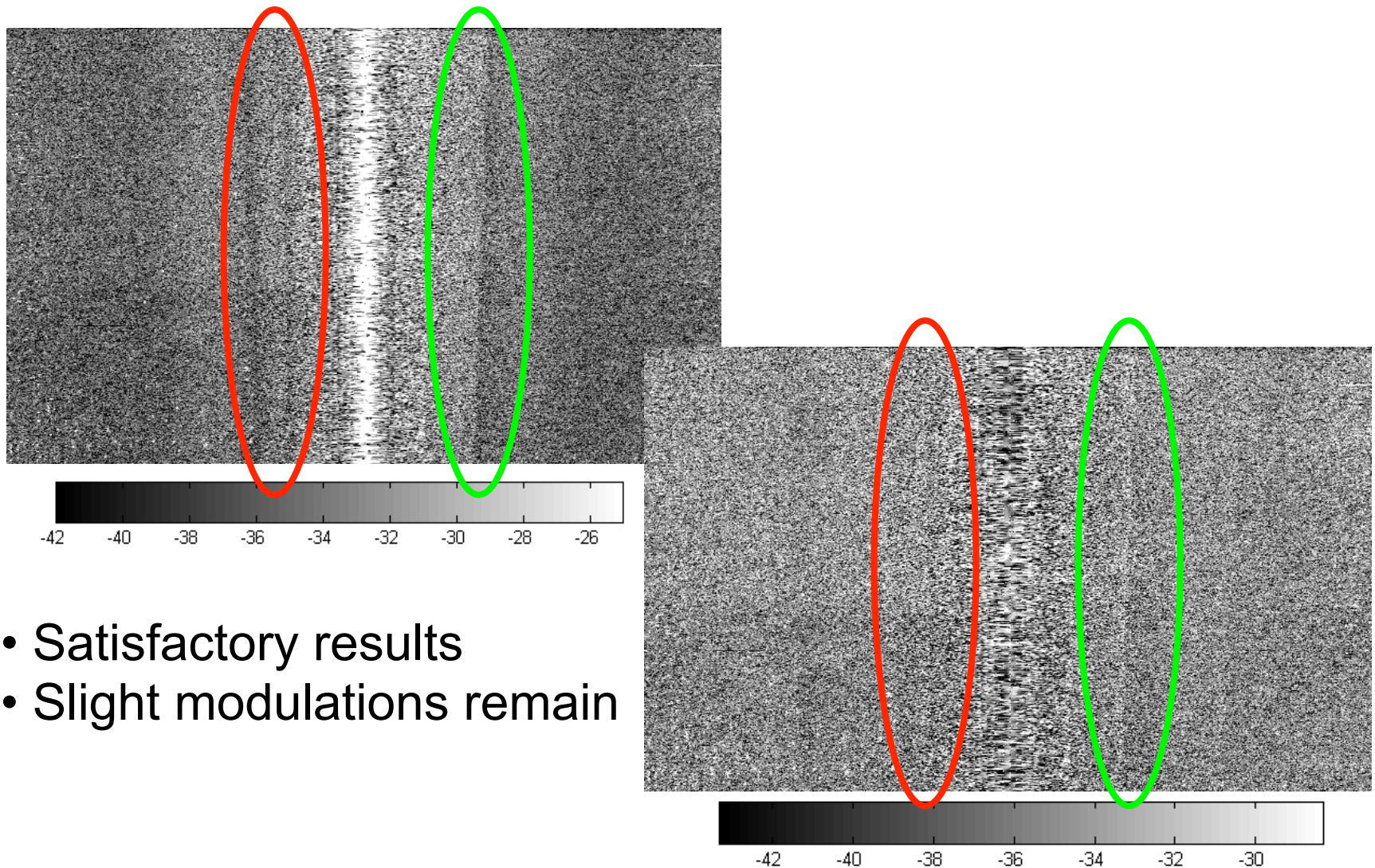

- Satisfactory results
- Slight modulations remain

Final statistical compensation result

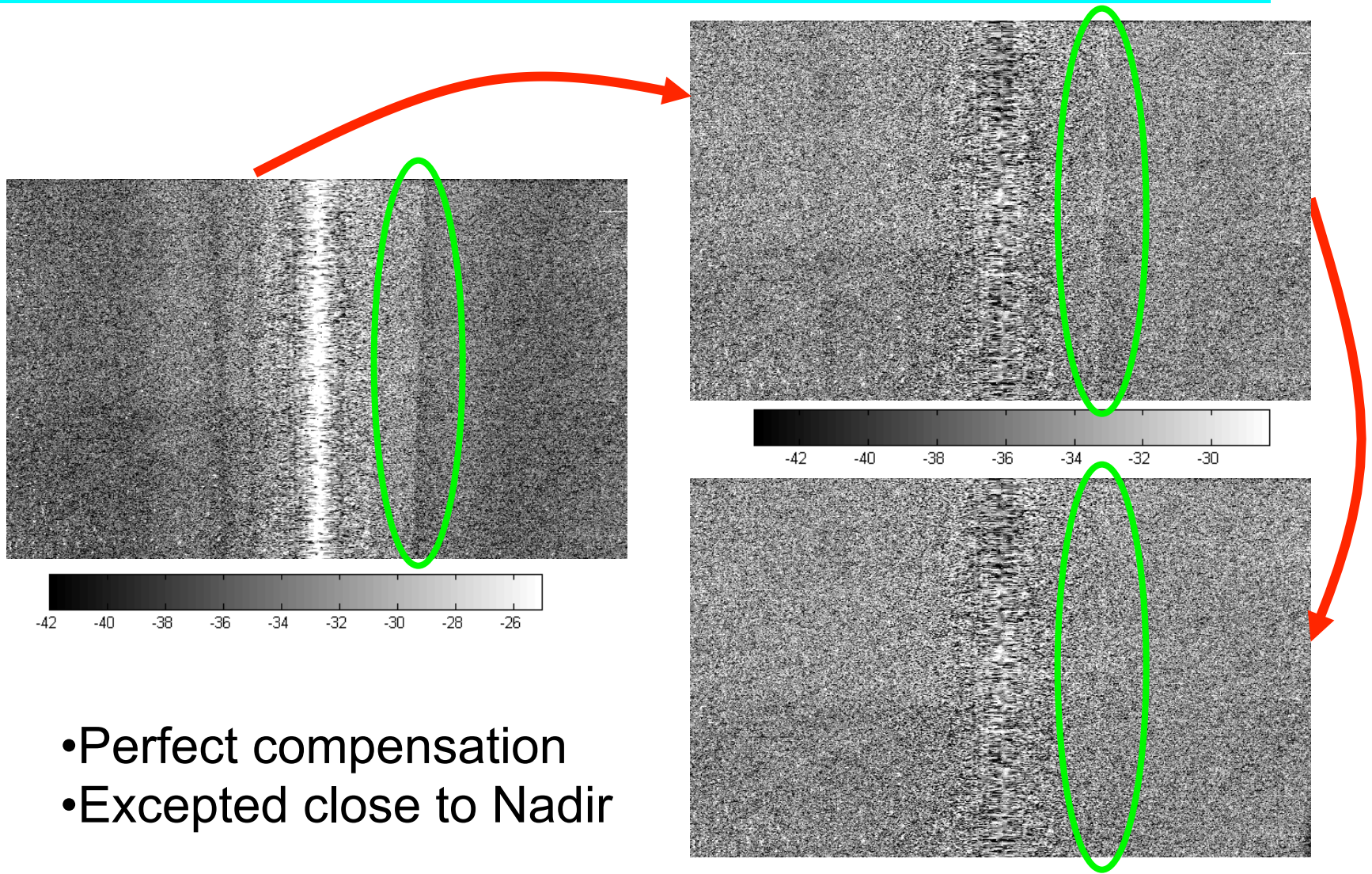

Backscatter Mapping today...

- Classical (soon a routine?): **Compensation** → **equalized images**
 - Transmission losses, footprint
 - Backscatter angular response
 - Sonar angular response
 - Image speckle filtering
- Work in progress:
 - **Topography** influence removal
 - Instruments **calibration**
- Missing today : general agreement on standardized items
 - **Calibration** procedures
 - as in Fishery sonar
 - Data **processing levels**
 - as in Radar see NASA Ref. Handbook 2006
 - **Angle reference** for Backscatter maps
 - as in Radar – 40°
 - ...

Outline

- ~~1. Backscatter in seafloor-mapping~~
- ~~2. Physical phenomena and modelling~~
- ~~3. Backscatter processing~~
- 4. A detour by outer Space**
5. MBES calibration issues
6. From backscatter data to seafloor characteristics
7. Discussions and prospective

4. A detour by outer Space

What are the neighbors (above) doing?



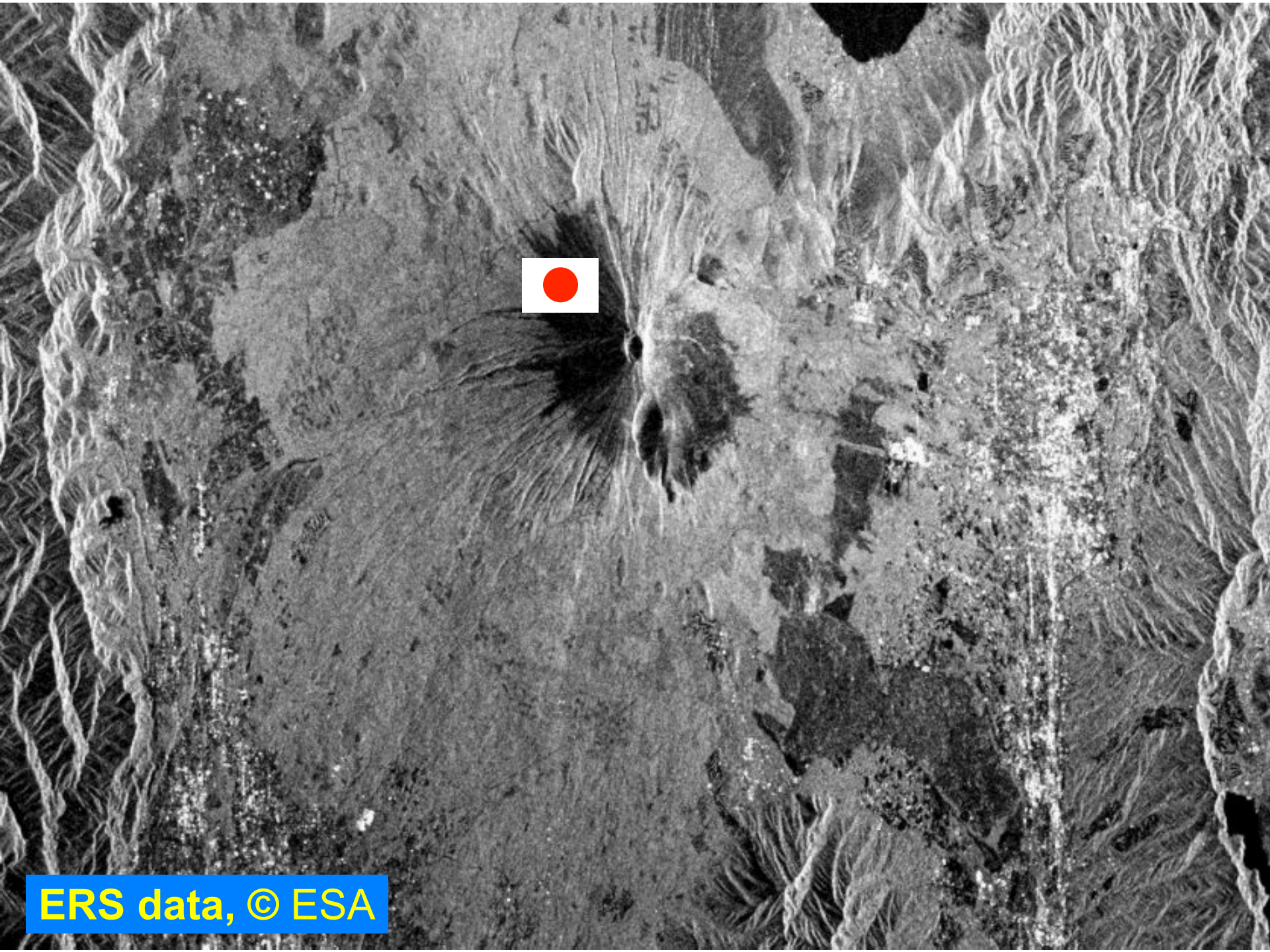

ERS data, © ESA

Air/Spaceborne SAR

- Similar/sonar: **swath geometry** → topography+ **radiometry**
- **Interface BS at oblique angles**
- Two scales of work → two instrument types
 - Classical SAR (imaging and topography) : V.High resolution (meter!!!)
 - Dedicated **Scatterometer** (BS mapping): low resolution
- Many practical applications in monitoring
- Calibration process well-defined & applied
- Compared/sonar:
 - Groundtruthing much easier (relatively)
 - Excellent positioning & motion
 - Swath geometry - Redundancy
 - Propagation losses

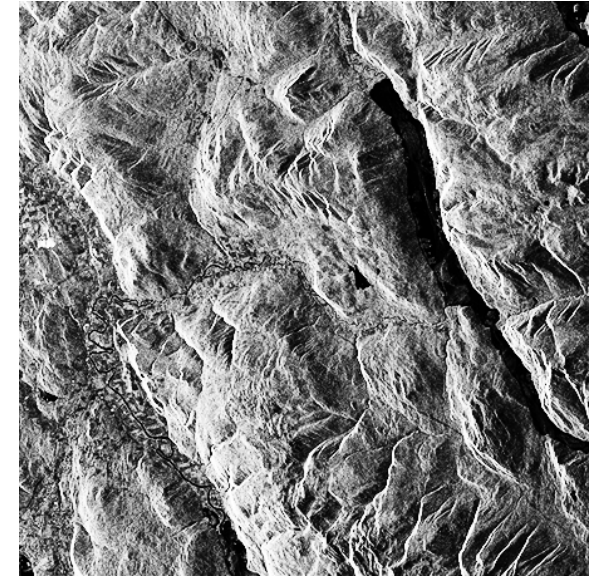

The ERS Scatterometer

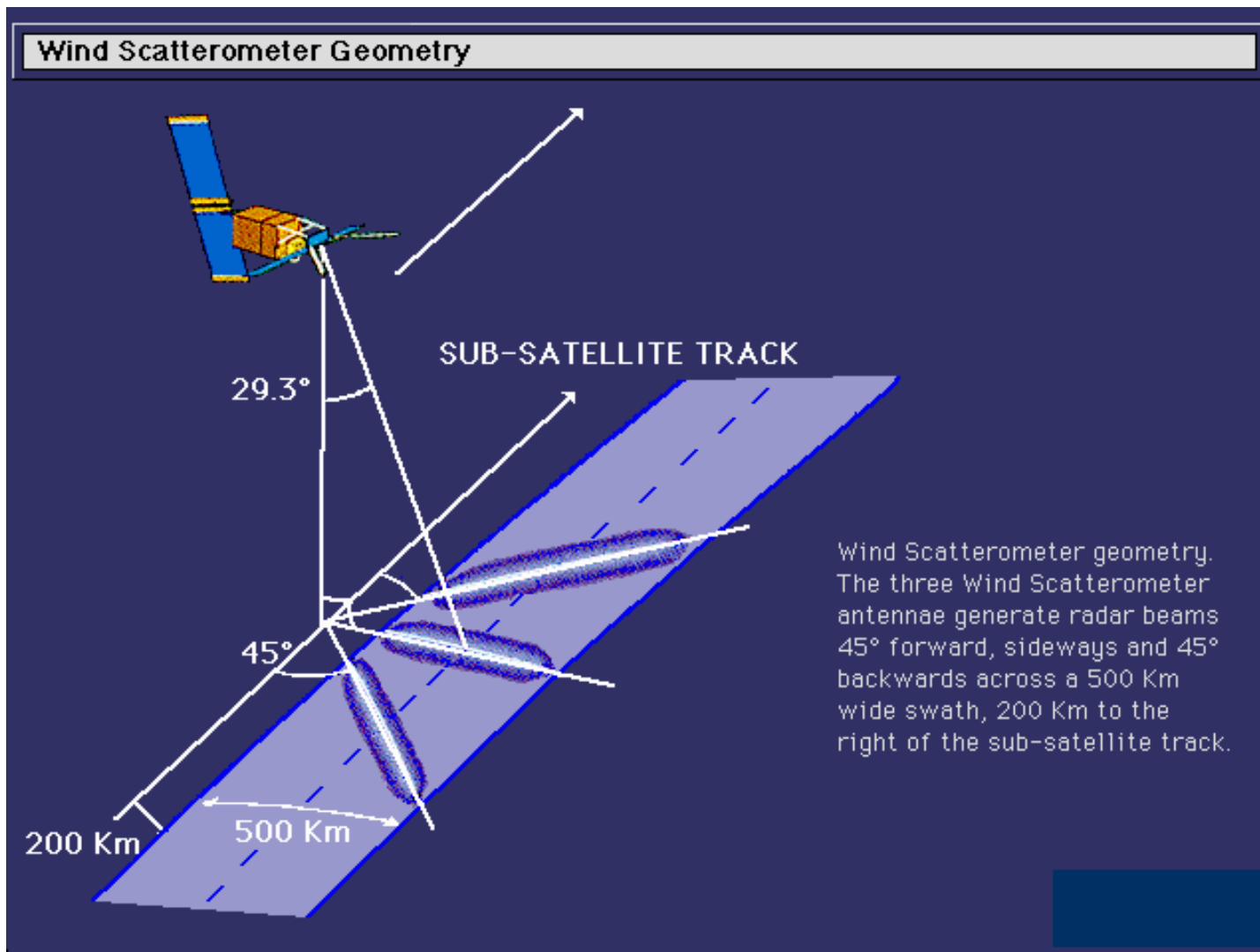

The ERS Scatterometer

- Strictly **large-scale BS measurement** functionality
 - Deliberately different from SAR imaging
- Swath 14° - 42° ; width 500 km / 3-azimuth angles $\pm 45^{\circ}$
- Low resolution (typ. 50 km)
- Simple array processing (no beamforming)
- Transmission loss:
 - Constant altitude, limited angle aperture
 - No significant absorption
- **Intensity calibration = paramount:**
 - Over natural reference area(s):
 - South-American rain forest
 - Dedicated instruments

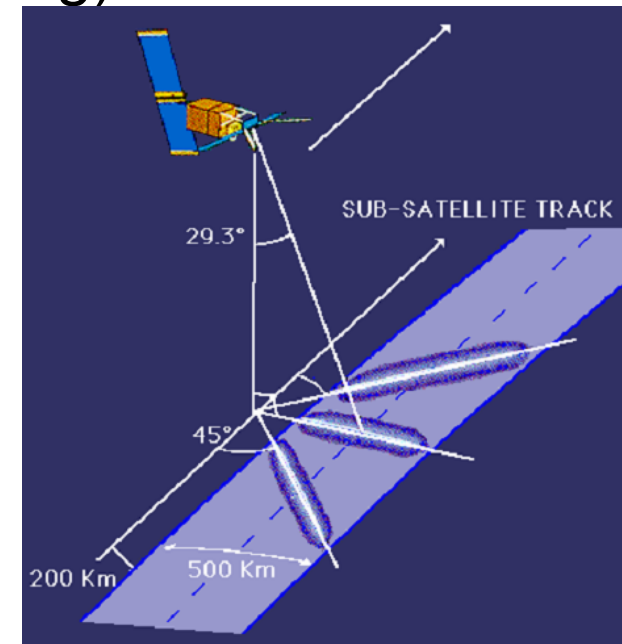

BS mapping / ERS Scatterometer

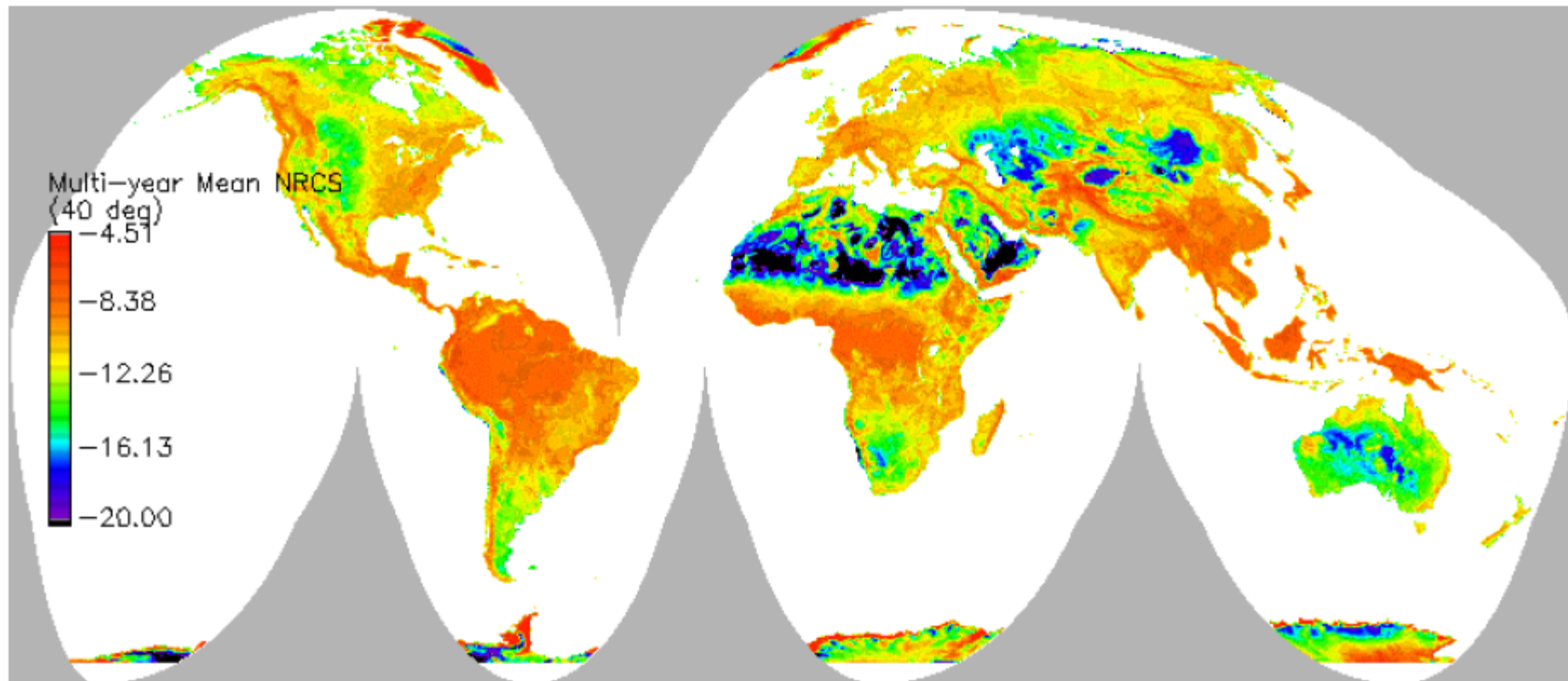

Figure 5 : Multi-Year Mean Sigma Nought at 40 Incidence Angle

BS mapping / ERS Scatterometer

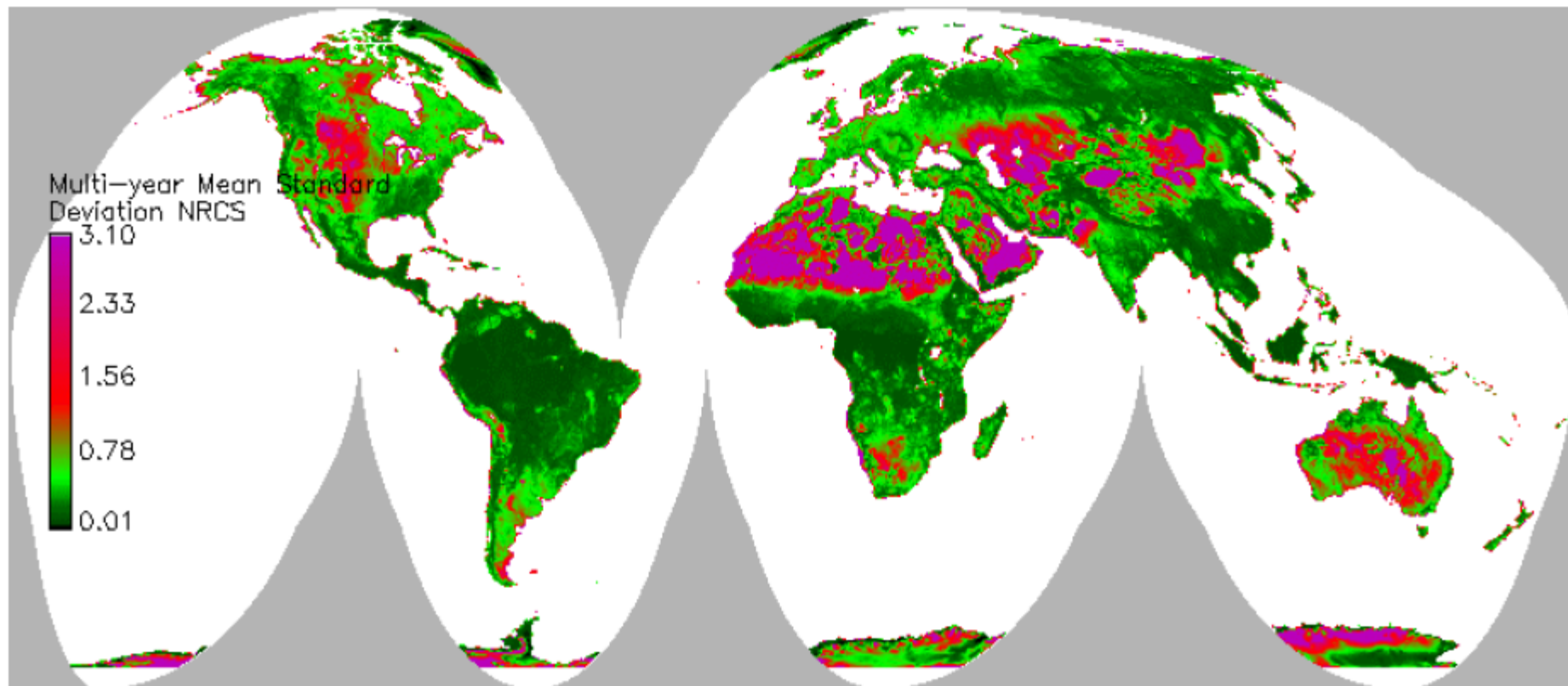

Figure 2 : Multi-Year Mean Standard Deviation in Sigma Nought

Scatterometer & SAR achievements

- Actual **monitoring applications**:

- Ocean / waves & wind
- Ice cover / Water / moisture
- Forest / Agriculture / Geology

Table 1.
Biomass sensitivity for Maritime and Loblolly Pine
(after Dobson *et al.*, 1992).

Band	Polarization	Linear Region (t/ha)	Biomass Sensitivity dB/t ha ⁻¹	dB Resolution for Error of 10 t/ha (±)
P	HH	1 to 200	0.12	1.2
P	HV	1 to 100	0.26	2.6
P	VV	1 to 50	0.08	0.8

- User's requirements** = well defined by community

- See Brown et al « SAR Application Calibration Requirements », CJRS, 1993

- Sensor **calibration**

- S.American rain forest
- Dedicated instruments

Table 3.
Summary of the calibration requirements by application
area for agriculture (in ± dB).

Application	Within Scene	Relative/ Between Scene	Absolute
Crop-type Determination	0.5	0.5	1.0
Soil Moisture	0.3	0.3	1.0
Crop Condition	0.1 to 0.25	0.1 to 0.25	<1.0
Conservation Farming	1.0	1.0	>1.0

- Absolute reflectivity measurement w/**accuracy** ≈ **±1 dB**

Outline

- ~~1. Backscatter in seafloor-mapping~~
- ~~2. Physical phenomena and modelling~~
 - ~~3. Backscatter processing~~
 - ~~4. A detour by outer Space~~
 - 5. MBES calibration issues**
6. From backscatter data to seafloor characteristics
 7. Discussions and prospective

5. MBES Calibration Issues

Intensity calibration for MBES

Required for:

- **Absolute measurements** of backscatter strength
- **Comparative measurements** w/one system (follow-up)
- **Inter-comparisons** of data from different systems 

A field already investigated by **fishery acoustics**

- Biomass estimation demand intensity calibration
- Techniques defined since the 1990' s
 - **Reference target spheres**
 - Accurate **positioning** (interferometry)
 - **Global response** measurement
- Well-adapted to single-beam sounders
 - Today extended to MBES (Simrad ME-70)

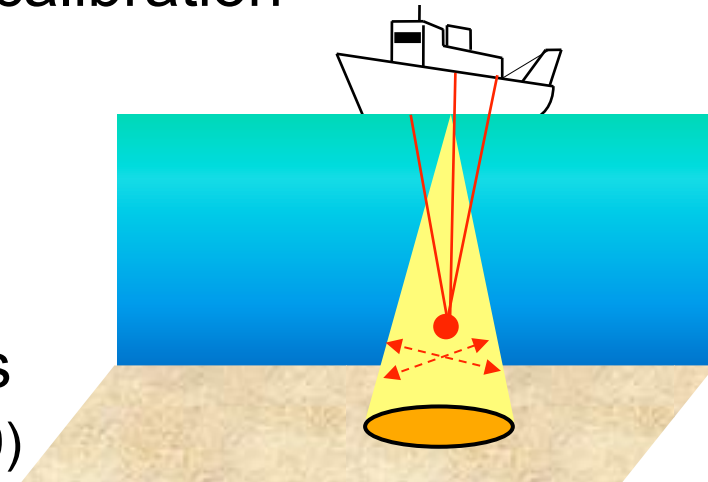

MBES calibration : possible approaches

- **Internal**
 - **Channel electronics response** (from reference voltages)
 - Lacks acoustic transducer response (impedance possible)
 - A good option for routine monitoring of the system
- **Separate Tx-Rx response**
 - Classical **sensitivity measurements** using recorders, sources...
 - Typically in-tank calibration
- **Overall response over a reference target**
 - Artificial target / constrained configuration
 - Natural area / operational context
- **Inter-calibration**
 - Use a **calibrated system as reference** (MBES, SBES)
 - Similar frequency & beamwidth
 - No reference target needed

MBES calibration : reference areas ?

- Standard acquisition over a **reference seafloor**
 - a straightforward operation
 - the target and configuration are the « normal » ones
 - concept \approx reference areas used for bathymetry calibration
- Main constraint: **prerequisites about the reference area:**
 - **Known absolute value** of BSs (vs angle and freq)
 - **Flat horizontal** topography
 - Local **homogeneity**
 - **Angular dependence** as regular as possible
 - **Stability** of the seafloor vs time
 - All this can be met for Radar targets – How about sonar?

➔ A topic for further thinking and discussion

Case Study #1 : EM 710 & 302 on *RV Falkor* (2)

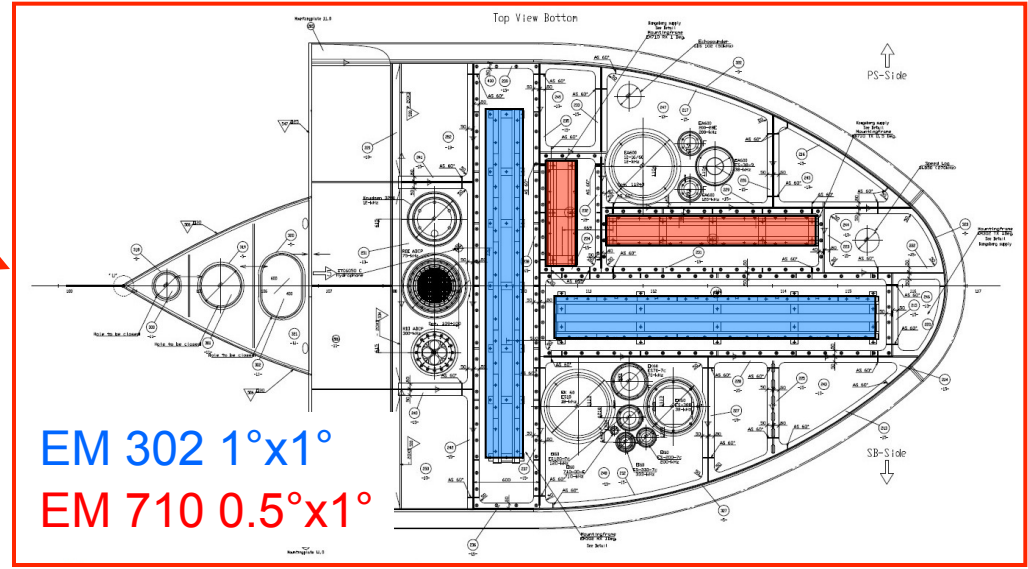
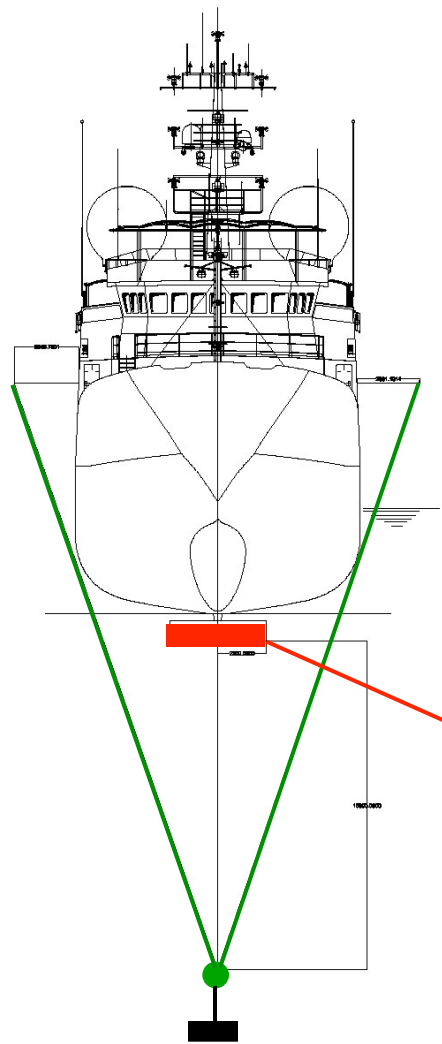



Case Study #1 :

EM 710 & 302 on *RV Falkor* (5)

EM 710

EM 302

Formed
Beams

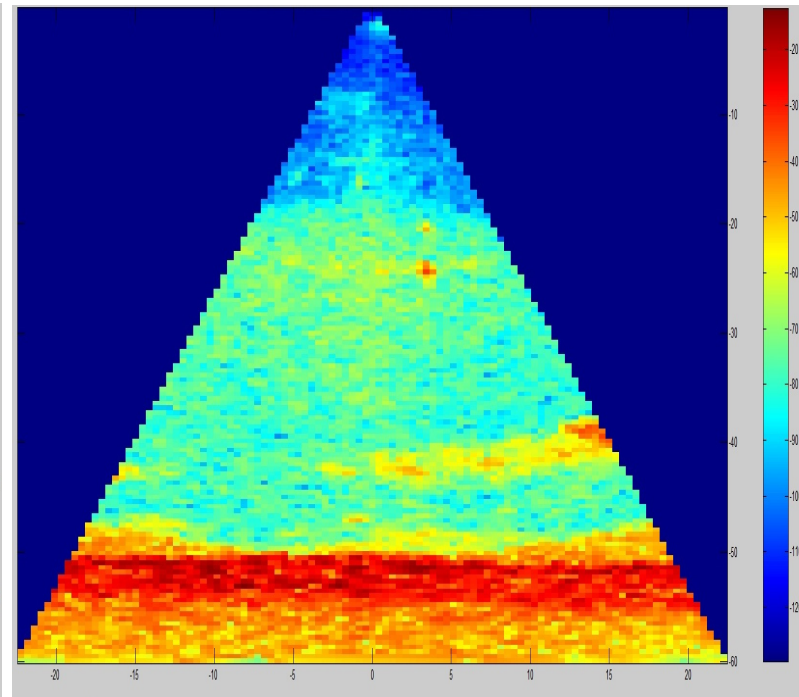
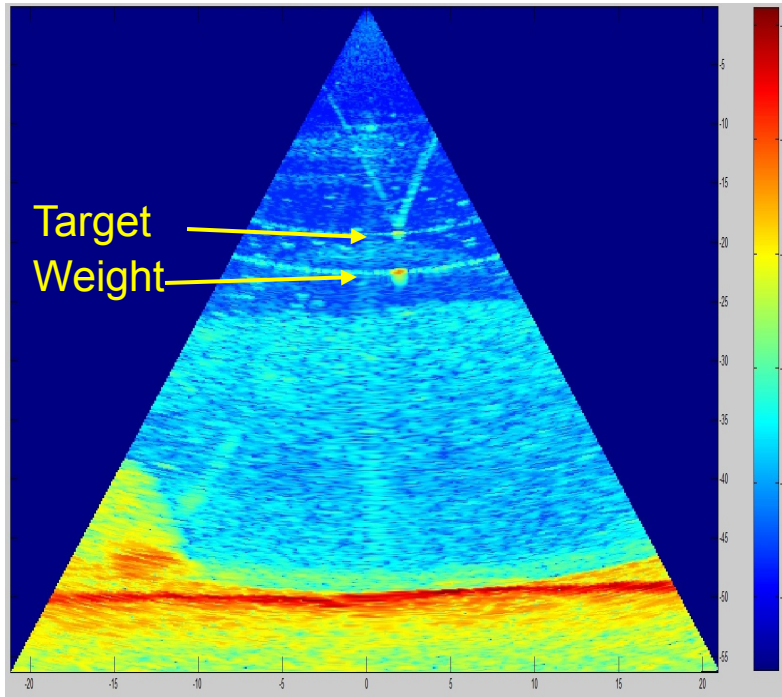

Stave
Raw Data

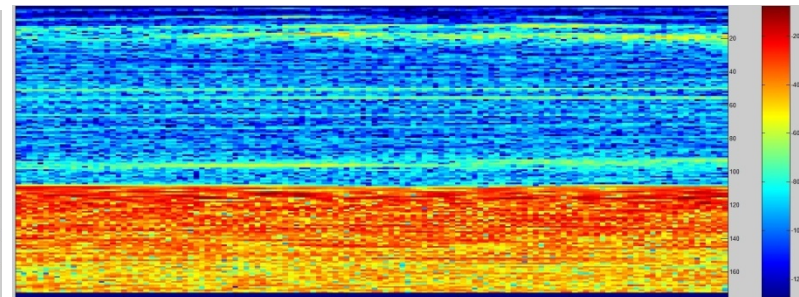
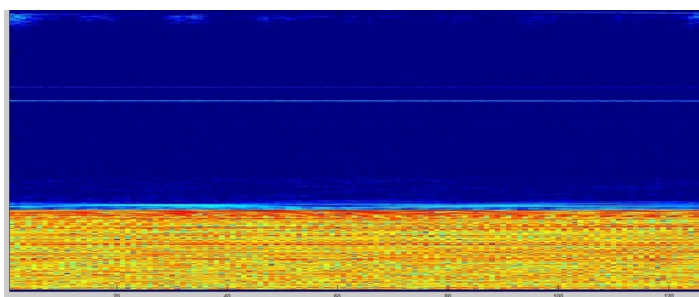

EM2040 calibration : Tank experiment



Tx

200kHz EK60

Rx

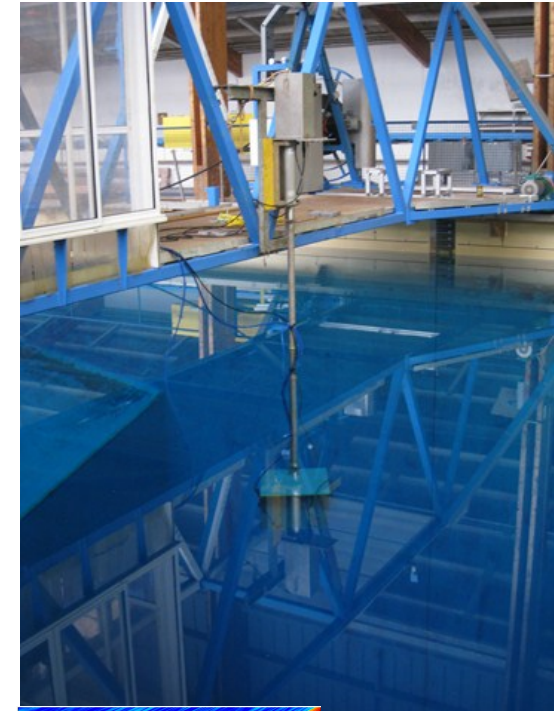

200/300/400 kHz

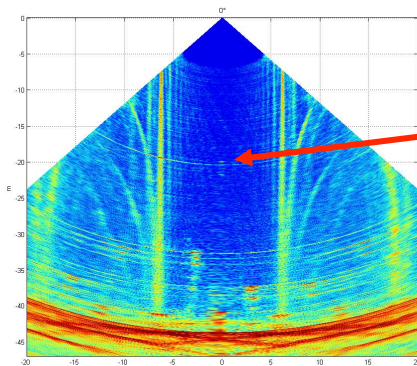

0°

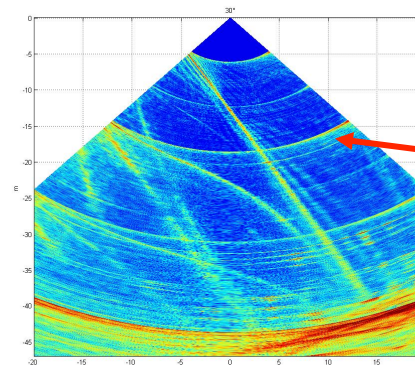
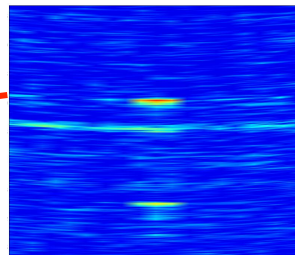

30°

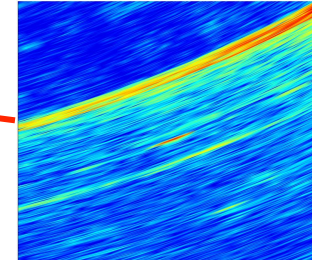

MBES Calibration today

- **BS measurement demands MBES calibration**
 - Still a **difficult emerging topic**, little practical solutions yet
- **No unique solution** fulfilling all systems
 - **Factory calibration** & documentation: **mandatory**
 - **In-tank calibration** = a **feasible** solution for HF systems
 - **At-sea calibration** (/ ref.target) = feasible w/difficulties
 - **Beams vs Staves** calibration???
- At-sea over **reference** areas : appealing but not credible
- Expected from **constructors** → new **functionalities** :
 - Generalized **BISTs**
 - **Tx and Rx automated scanning** sequences
 - **Application and logging** tools of compensation values



Outline

~~1. Backscatter in seafloor-mapping~~

~~2. Physical phenomena and modelling~~

~~3. Backscatter processing~~

~~4. A detour by outer Space~~

~~5. MBES calibration issues~~

6. From backscatter data to seafloor characteristics

7. Discussions and prospective

6. From backscatter data to seafloor type and characteristics

Model Inversion

- Data + Model + Inversion tool → Expected parameters values
 1. BS data → acoustical parameters
 2. Acoustical → Geological parameters
- Very often addressed = technical aspects:
 - Inversion strategies
 - Invertibility, number of parameters, constraints...
 - Ambiguities, local minima...
- **The actual issue: how relevant is the model to invert ???**
 - Which model to be used on an unknown seafloor type?
 - How reliable is the physical description of one *a priori* model?
- If the model is not adapted, what is the point of **inversion**?

BS model limitations for Inversion

- Context: fluid sediment / Jackson's model
- Computation for 9 sediments @ 12 & 70 kHz:
 - $Z_{\text{sed}}/Z_{\text{water}}$ varying from 1.2 to 3.6 (dynamics ≈ 15 dB)
 - **Same interface roughness ; same volume index**

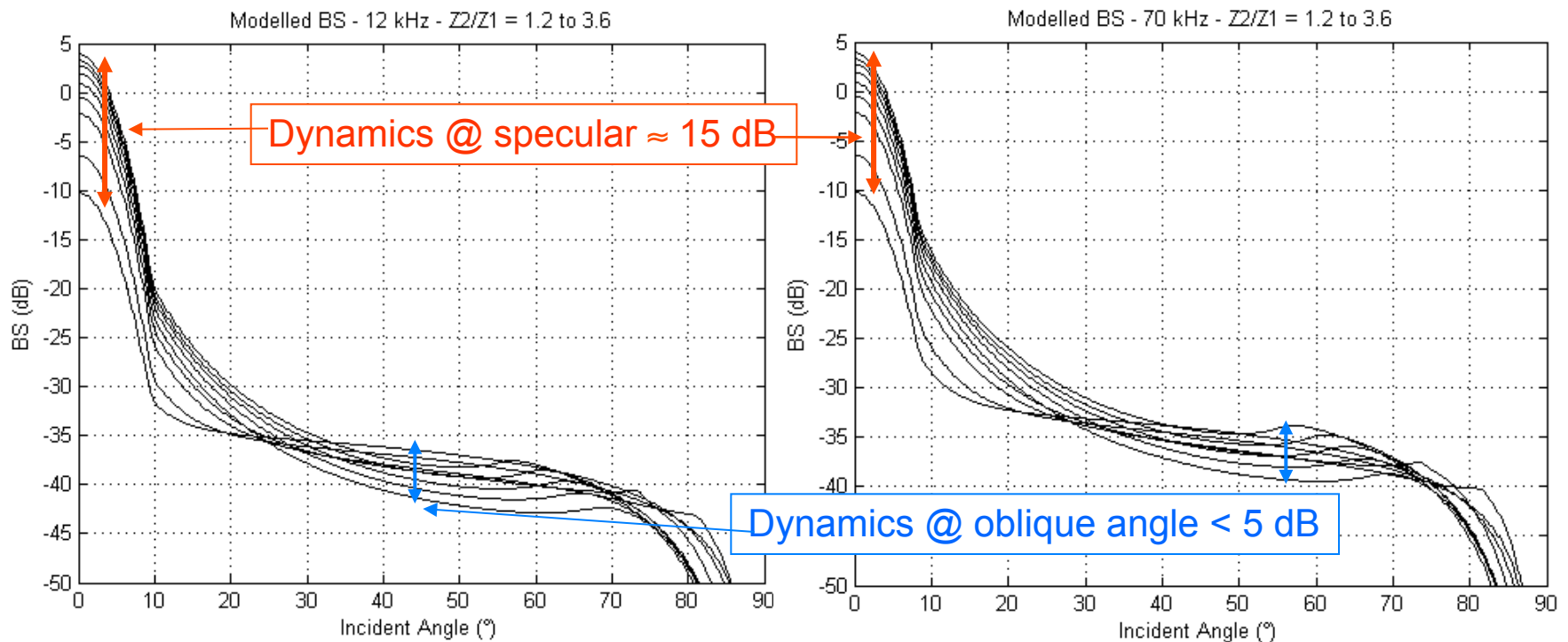

Inversion : BS model Ambiguities (2)

- The Jackson's model $BS(\theta)$ essentially provides information about:
 - **roughness and volume** - at oblique & grazing incidences
 - impedance contrast - only at specular incidence
- Possible correlation between sediment properties and roughness / volume?
- However, for most of the swath width, little information is available from $BS(\theta)$ about the sediment bulk characteristics
- Moreover, *a priori* hypotheses have been made when choosing **this particular model**

Inversion : BS model Ambiguities (3)

- **Inversion results depend first on the model** applied
- A “**successful**” inversion can imply both:
 - A **technically satisfying result** of the inversion process
 - e.g.: Convergence +++, no determination ambiguities...
 - And **pointless parameter values**
 - e.g.: Volume BSv in a rock seafloor
- Chances are that practically the model parameters do not really embody what they are supposed to...
- ... in this case why not using **a simpler model with catch-all parameters?**

Empirical Classification

- A functional model of $BS(\theta)$
 - $BS = A \cdot \exp(-\theta^2/B) + C \cdot \cos^D \theta$
 - Limited set of parameters
 - General agreement w/ physical response
- Fit of model with recorded data
- Build a direct correspondence with **seafloor type / ground-truthing**

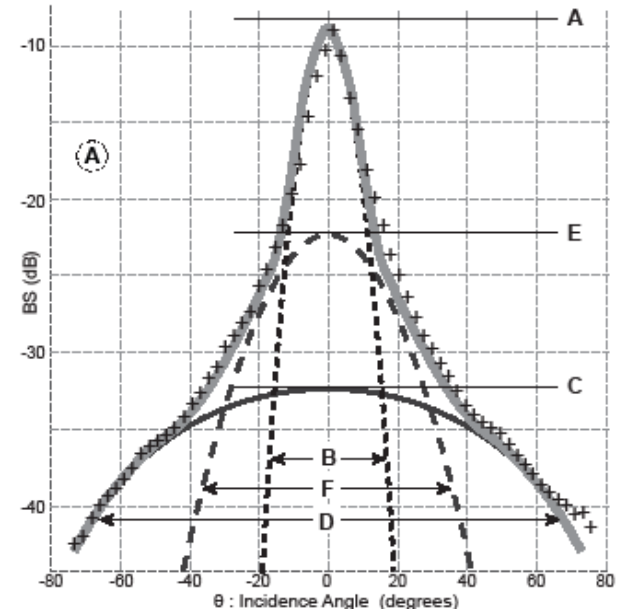
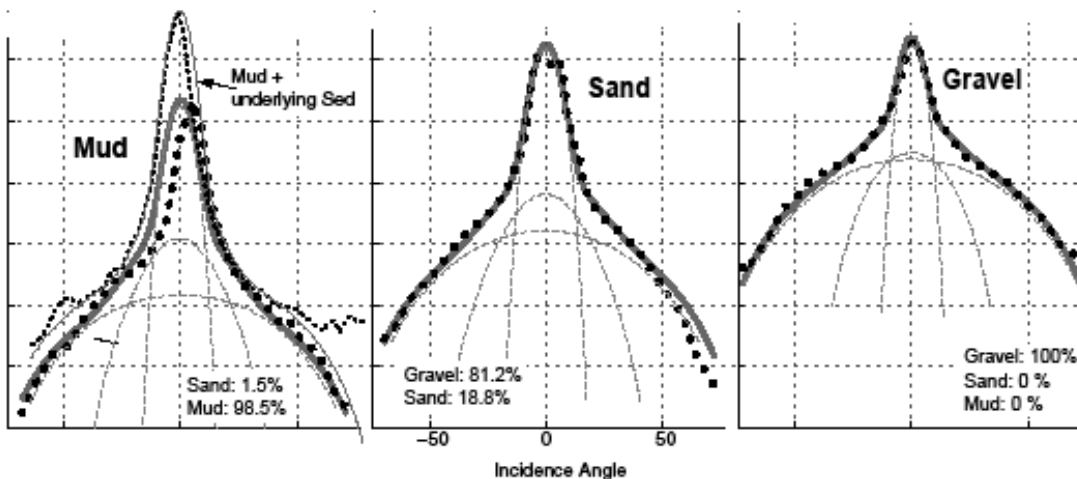

	Mud	Sand	Gravel
A	-13.6	-9.1	-9.1
B	5.5	5.9	4.9
C	-29.1	-23.9	-17.9
D	2	2	2

(From Lamarche et al, CSR, 2010)

Bs(θ) to seafloor type : Two approaches

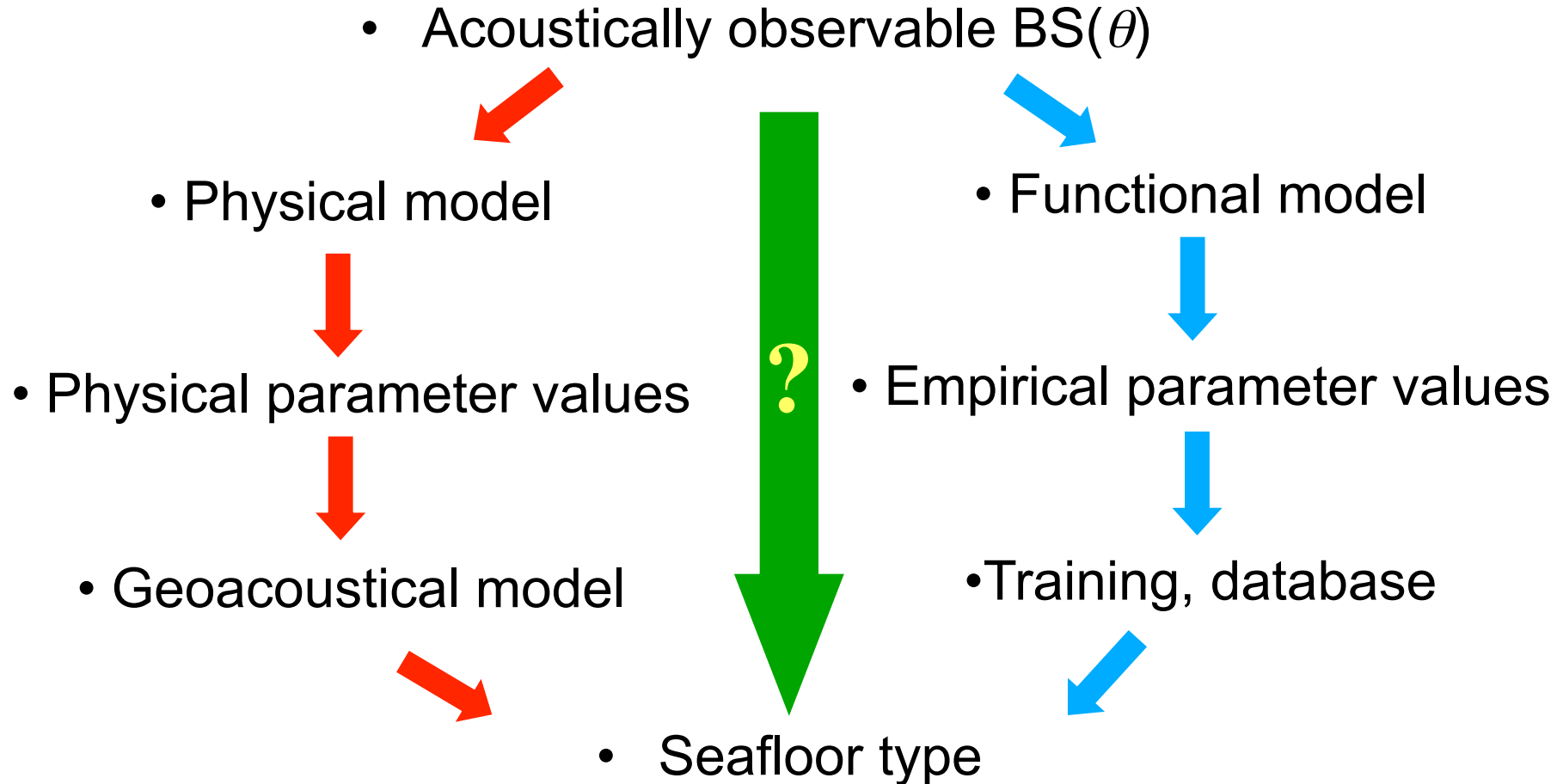

From reflectivity to geological properties ?

Many obstacles :

- Need to define an ***a priori* geoacoustical model**
 - Multi-layers? Interface scatterers? ...?
- Acoustic scattering : lack of **reliable and practical models**
 - Little alternative between heuristical and over-detailed/specialized
- **Inversion / optimisation** : an ill-posed problem
 - Poor information in the signal content
 - Too many parameters in the models
- Relations between **acoustical and geological parameters**
 - **Major acoustically significant features** (roughness, inhomogeneity, gas...) **not accounted for in geological approach**

Outline

- ~~1. Backscatter in seafloor-mapping~~
- ~~2. Physical phenomena and modelling~~
 - ~~3. Backscatter processing~~
 - ~~4. A detour by outer Space~~
 - ~~5. MBES calibration issues~~
- ~~6. From backscatter data to seafloor characteristics~~
- 7. Discussions and prospective**

Discussions & Perspective

What is expected, exactly?

Where do we go from here?

Some pending (and concerning) issues

- What are exactly the **user's expectations**?
- How relevantly do we (try to) **model seafloor backscatter**?
 - Which **reality** is **actually accessible** through models & analysis?
 - How do we relate it to user's expectations for habitat mapping?
 - What is the point today of **inverting available models**?
- Are we working at the **appropriate scale**?
 - Sonar **image** vs Backscatter **measurement** ?
 - Are we using **well-adapted sensors**?
 - Is it realistic to use the whole swath (w/specular and grazing)?
- Can we hope **reliable absolute calibration** of today MBES?
 - Do we need it?
 - How reliable are field data in this respect?

Recommendations

- Specify better the **user's requirements**
 - dB-accuracy ; horizontal scale
- Improve **strategies in data acquisition**
 - Closer lines...
 - Forget the specular and grazing regimes (Radar!)
- Sensibilize users and manufacturers to **calibration** issues
- Develop **SW tools** for
 - 3-D Topography compensation
 - System calibration : in factory and in-situ
 - Sensor response compensation
- Build a **database of pragmatic backscatter descriptors**
 - Seafloor types, frequencies, angles
 - A joint effort of the community?

Recommendations

- Define common **standards for data processing and display**
 - Processing flow-charts
 - Equivalent BS @45°?
- Think of **new approaches**
 - Multi-frequency? Multi-sensors? Multi-angles?
 - Natural reference areas for calibration?
- Design **new instruments**
 - From existing ones → new modes
 - From the scratch : a sonar scatterometer?
- Investigate the **water column effect**
 - Surface aeration, interface layer



Questions?

